



Swansea University  
Prifysgol Abertawe



## Cronfa - Swansea University Open Access Repository

---

This is an author produced version of a paper published in:  
*Chemical Engineering Research and Design*

Cronfa URL for this paper:  
<http://cronfa.swan.ac.uk/Record/cronfa41131>

---

### **Paper:**

Ejeh, J., Liu, S. & Papageorgiou, L. (in press). Optimal multi-floor process plant layout with production sections.  
*Chemical Engineering Research and Design*  
<http://dx.doi.org/10.1016/j.cherd.2018.07.018>

12 month embargo.

---

This item is brought to you by Swansea University. Any person downloading material is agreeing to abide by the terms of the repository licence. Copies of full text items may be used or reproduced in any format or medium, without prior permission for personal research or study, educational or non-commercial purposes only. The copyright for any work remains with the original author unless otherwise specified. The full-text must not be sold in any format or medium without the formal permission of the copyright holder.

Permission for multiple reproductions should be obtained from the original author.

Authors are personally responsible for adhering to copyright and publisher restrictions when uploading content to the repository.

<http://www.swansea.ac.uk/library/researchsupport/ris-support/>

## Accepted Manuscript

Title: Optimal multi-floor process plant layout with production sections

Author: Jude O. Ejeh Songsong Liu Lazaros G. Papageorgiou

PII: S0263-8762(18)30357-5  
DOI: <https://doi.org/doi:10.1016/j.cherd.2018.07.018>  
Reference: CHERD 3272



To appear in:

Received date: 9-2-2018  
Revised date: 16-6-2018  
Accepted date: 12-7-2018

Please cite this article as: Jude O. Ejeh, Songsong Liu, Lazaros G. Papageorgiou, Optimal multi-floor process plant layout with production sections, *Chemical Engineering Research and Design* (2018), <https://doi.org/10.1016/j.cherd.2018.07.018>

This is a PDF file of an unedited manuscript that has been accepted for publication. As a service to our customers we are providing this early version of the manuscript. The manuscript will undergo copyediting, typesetting, and review of the resulting proof before it is published in its final form. Please note that during the production process errors may be discovered which could affect the content, and all legal disclaimers that apply to the journal pertain.

**Highlights**

*Optimal multi-floor process plant layout with production sections*

- Simultaneously addresses multi-floor site and plot process plant layout;
- Case studies of up to 22 units and 6 production sections;
- Globally optimal solutions in as early as 12 mins for the 22-unit case;
- Models with production sections outperform those without production sections.

Accepted Manuscript

## OPTIMAL MULTI-FLOOR PROCESS PLANT LAYOUT WITH PRODUCTION SECTIONS

Jude O. Ejeh<sup>a</sup>, Songsong Liu<sup>b</sup>, Lazaros G. Papageorgiou<sup>a,\*</sup>

<sup>a</sup>Centre for Process Systems Engineering, Department of Chemical Engineering, University College London, London WC1E 7JE, UK

<sup>b</sup>School of Management, Swansea University, Bay Campus, Fabian Way, Swansea SA1 8EN, UK

---

### Abstract

This paper addresses the multi-floor process plant layout problem by developing four mixed integer linear programming (MILP) models. The problem involves decisions concerning the optimal spatial arrangement of process plant equipment and/or auxiliary units considering equipment connectivity, pumping and construction costs, and other factors. These considerations are extended to account for tall equipment that spans across floors and the availability of pre-defined production sections. The proposed models determine simultaneously the number of floors per section, floor areas, plot layout and site layout, and are applied to two case studies with up to 22 units and 6 production sections to demonstrate their applicability.

*Keywords:* multi-floor process plant layout, mixed integer linear programming (MILP), production sections, optimisation

---

### 1. Introduction

The design of a chemical process plant involves the application of scientific theories and principles, with engineering judgement, to develop an idea from the conceptual stage until completion [22]. This process typically involves feasibility studies of the economics and market, design data development, detailed engineering designs and economics, procurement and construction, with step by step result testing [22]. The detailed engineering designs comprise the estimation of process operating conditions, equipment specifications, costs and overall layout; with the last consideration of particular concern to this work.

Chemical process plant layout design seeks to determine how best equipment and associated structures required can be placed within a given physical location, considering their interconnections, the general safety and operability of the plant, as well as the ease and efficiency of construction and operation [14].

---

\*Corresponding author. Tel: +44 (0)20 7679 2563  
Email address: l.papageorgiou@ucl.ac.uk (Lazaros G. Papageorgiou)

In practice, layout considerations can be separated into three as outline by Moran[14] in a "brownfield": *site layout* - relating to how plots are placed relative to each other in a site; *plot layout* - layout of process units within a plot; and *equipment layout* - arranging process units auxiliaries about the individual unit [14]. The final layout can then be determined through a combination of intuition, economic optimisation, critical examination, equipment ratings, mathematical modelling, and/or 3D CAD software; the first method being regarded as informal and less deterministic.

A more precise and informed approach is by mathematical modelling, where models are solved by proven algorithms to determine an optimal layout based on predefined conditions. This method has gained popularity in the past three decades amongst researchers and quite a number of models have been developed over time. The primary focus has been given to the realisation of a minimal cost [4]. This cost relates to equipment interconnections by pipes, horizontal and vertical pumping [4, 17], installation of safety equipment [21], in a single floor and multi-floor scenario [19]; considering equipment representations in 2D and 3D with irregular shapes [1]. The mathematical models, most times, have been formulated as mixed integer non-linear programming (MINLP) [21] or mixed integer linear programming (MILP) models [1, 20], being able to handle a few process units in modest computational times. Improved algorithms [20, 24] have also been developed to successfully handle more process units, but recent works have employed other solution techniques [3, 8, 15, 16, 18, 23].

Multi-floor layout considerations in process plants have become important in recent times owing to growing concerns of space availability, exorbitant land costs, the need to save land for future extensions [6] or where the available layout area already has multiple floors, e.g., in offshore platforms [10]. Also, the existence of tall equipment that spans across floors (which is quite prevalent in most chemical processes) inadvertently presents a multi-floor scenario. These have led to a number of factors being considered in the literature as it relates to multi-floor layout: routing and layout of pipes [5], safety and risk assessment [13, 23], tall equipment [7, 10, 23], area minimisation [9], to name a few. However, consideration of production sections/segregations has not been given much attention, though its widespread practice. With production sections/segregations, different parts of the entire chemical process plant are grouped and placed adjacent to each other [12] in what can be referred to as a plot layout [14]. Such groupings aid in safety and loss prevention, housekeeping, and efficient construction and maintenance of equipment [12]. Papageorgiou and Rotstein [17] proposed a mathematical modelling approach for single-floor process plant layout with production sections. Equipment was pre-allocated sections and the optimal layout within each section and amongst sections was simultaneously determined. Results showed an increase in total cost due to sectioning, but the formulation could only handle a limited number of units in a single floor case. This work seeks to present mathematical models to handle larger scale multi-floor process plant layouts in production sections, with tall equipment that spans across floors.

The considerations in this work constitute an extension of the work by Ejeh et al. [2], where MILP models were proposed to obtain the optimal multi-floor layout

of a plant considering tall equipment spanning multiple floors with connections at design-specified heights amongst equipment. Model solutions gave the optimal number of floors, equipment floor location and position considering connection, construction and pumping costs. Four models (broadly divided into formulations A and B based on the modelling of tall equipment) were proposed. In formulation A, tall equipment was modelled as a single continuous unit spanning through floors by three alternative sets of equations. In formulation B, tall equipment was split into single-floor pseudo units occupying contiguous floors. Each of these models was tested with case studies of up to 17 units and optimal solutions were obtained in reasonable computational times. In this work, production sections are introduced and the optimal number of floors and area per section are determined.

In the remaining part of this paper, [section 2](#) gives a description of the problem to be solved; the mathematical formulation is described in [section 3](#); and case studies are presented in [section 4](#) to show the model performance and features. Finally, concluding remarks of the major findings are highlighted in [section 5](#).

## 2. Problem Description

This work aims to obtain the optimal multi-floor process plant layout with pre-defined production sections. The production section is the key feature of the problem in this work and refers to a well-defined rectangular area spanning across floors containing a pre-defined subset of equipment items. This feature promotes plant safety, operability, maintenance activity and workforce management.

Throughout this paper the following assumptions are made:

- The geometries of all process plant equipment and production sections are approximated as rectangles.
- Distances between equipment and/or sections are rectilinear from their geometrical centres in the x-y plane. Vertical distances are taken from a design-specified height on the equipment unique to each case study.
- Each equipment must belong to only one section, and such section is pre-defined.
- Each of the available sections starts from the ground floor upwards, having an optimal number of floors less than or equal to the total number of available floors.
- The position coordinates of production sections are calculated with respect to the origin of the base land area, and the equipment position coordinates with respect to the origin of the production section to which they belong.
- Both equipment and production sections can be rotated  $90^\circ$  in the x-y plane as deemed optimal, but must start from the base of the floor it has been assigned.

- Any equipment with a height greater than the floor height is allowed to extend through contiguous floors.

The problem description is given as follows.

*Given:*

- a set of process units and their dimensions (length, depth and height);
- a set of sections with equipment allocation;
- a set of potential floors;
- connectivity network amongst process units;
- cost data (connection, pumping, land, and construction);
- floor height;
- space and unit allocation limitations;
- minimum safety distances between process units;

*to determine:*

- total number of required floors for each section for the layout;
- base land area occupied;
- area of floors;
- area of each section and the floors in which they are located;
- site and plot layout;

*so as to:* minimise the total plant layout cost associated with connection, pumping, land purchase and floor construction across production sections.

### 3. Mathematical Formulation

#### Nomenclature

##### *Indices*

$i, j$	equipment item in models A.1 - A.3
$i', j'$	equipment item in model B
$k$	floor number
$s$	rectangular area sizes
$t, u$	sections/production modules

*Sets*

$I$	set of equipment item for models A.1 - A.3
$I'$	set of equipment item for model B; $I' = (I \setminus MF) \cup \bigcup_{i \in MF} P_i$
$I_t$	set of equipment item $i$ in section $t$
$I'_t$	set of equipment item $i'$ in section $t$
$MF$	set of multi-floor equipment
$P_i$	sets of pseudo units for multi-floor equipment $i$
$P^1$	set of pseudo units of each multi-floor equipment item $i$ assigned to the lowest floor

*Parameters*

$BM, BM'$	large numbers
$C_{ij}^c$	connection costs between items $i$ and $j$
$C_{ij}^h$	horizontal pumping costs between items $i$ and $j$
$C_{ij}^v$	vertical pumping costs between items $i$ and $j$
$De_{ij}^{min}$	minimum safety distance between items $i$ and $j$
$Ds_{tu}^{min}$	minimum safety distance between sections $t$ and $u$
$f_{ij}$	1 if flow direction between equipment items $i$ and $j$ is positive; 0, otherwise
$FC1$	fixed floor construction cost
$FC2$	area-dependent floor construction cost
$LC$	land cost
$M_i$	number of floors required by equipment item $i$
$\bar{X}_s, \bar{Y}_s$	x-y dimensions of pre-defined rectangular area sizes $s$

*Integer variables*

$NF^{max}$	maximum number of floors required across all sections
$NF'_t$	number of floors required by section $t$

*Binary variables*

$N_{ij}$	1 if items $i$ and $j$ are assigned to the same floor; 0, otherwise
$Q'_{st}$	1 if rectangular area $s$ is selected for section $t$ in the layout; 0, otherwise
$S1_{tu}, S2_{tu}$	non-overlapping binary, a set of values which prevents production section overlap in one direction in the x-y plane
$S_{ik}^s$	1 if item $i$ begins on floor $k$ ; 0, otherwise
$V_{ik}$	1 if item $i$ is assigned to floor $k$
$W'_{kt}$	1 if floor $k$ in section $t$ is occupied; 0, otherwise



*Continuous variables*

$A_{ij}$	relative distance in y coordinates between items $i$ and $j$ , if $i$ is above $j$
$AR'_{st}$	predefined rectangular floor area $s$ for section $t$
$B_{ij}$	relative distance in y coordinates between items $i$ and $j$ , if $i$ is below $j$
$d_i$	breadth of item $i$
$dt_t$	breadth of production section $t$
$FA$	base land area
$FA'_t$	area of section $t$
$FA2'_{kt}$	area of floor $k$ in section $t$
$l_i$	length of item $i$
$L_{ij}$	relative distance in x coordinates between items $i$ and $j$ , if $i$ is to the left of $j$
$lt_t$	length of production section $t$
$NQ'_{st}$	linearisation variable expressing the product of $NF'_t$ and $Q'_{st}$
$R_{ij}$	relative distance in x coordinates between items $i$ and $j$ , if $i$ is to the right of $j$
$TD_{ij}$	total rectilinear distance between items $i$ and $j$
$x_i, y_i$	relative coordinates of the geometrical centre of item $i$
$xt_t, yt_t$	absolute coordinates of the geometrical centre of production section $t$ on base land area
$X^{max}, Y^{max}$	dimensions of base land area

The mathematical formulation constitutes an extension to the formulations proposed by Egeh et al. [2] as summarized in Appendix A. These formulations are broadly classified into "A" and "B". In formulation A, tall equipment is modelled as a single continuous unit spanning across contiguous floors, and three equivalent sets of equations (models A.1, A.2 and A.3) are proposed to describe this. In formulation B, tall equipment is split into single floor pseudo-units equivalent to the number of floors such equipment will span through. The pseudo-units are then assigned to the same positions on consecutive floors, and the model determines the optimal starting floors. All of these considerations, however, ignore production section restrictions. These four models (Models A.1, A.2, A.3 and B) are thus modified, with new constraints introduced. These constraints prevent overlapping amongst sections and allow for placement of equipment in the appropriate section. It also builds on the model proposed by Papageorgiou and Rotstein[17] to account for production sections but further determines the optimal number and size of floors per section:

*3.1. Formulation A*

Formulation A consists of three alternative sets of equations for the tall equipment. For each of these equations, in order to prevent overlap of production

sections on each floor  $k$ , the following additional equations are introduced:

$$xt_t - xt_u + BM(S1_{tu} + S2_{tu}) \geq \frac{lt_t + lt_u}{2} + Ds_{tu}^{min} \quad \forall t, u > t \quad (1)$$

$$xt_u - xt_t + BM(1 - S1_{tu} + S2_{tu}) \geq \frac{lt_t + lt_u}{2} + Ds_{tu}^{min} \quad \forall t, u > t \quad (2)$$

$$yt_t - yt_u + BM(1 + S1_{tu} - S2_{tu}) \geq \frac{dt_t + dt_u}{2} + Ds_{tu}^{min} \quad \forall t, u > t \quad (3)$$

$$yt_u - yt_t + BM(2 - S1_{tu} - S2_{tu}) \geq \frac{dt_t + dt_u}{2} + Ds_{tu}^{min} \quad \forall t, u > t \quad (4)$$

where  $S1_{tu}$  and  $S2_{tu}$  are binary variables with pairs of values determining which of equations (1) - (4) is active. For example, if  $S1_{tu} = 0$  and  $S2_{tu} = 0$ , equation (1) becomes  $xt_t - xt_u \geq \frac{lt_t + lt_u}{2} + Ds_{tu}^{min}$  ensuring that the position of section  $t$  is always a distance to the right of section  $u$  of at least  $Ds_{tu}^{min}$ .  $Ds_{tu}^{min}$  represents the minimum safety distance between sections  $t$  and  $u$ , and must be greater than or equal to the minimum safety distance ( $De_{ij}^{min}$ ) between equipment  $i \in I_t$  and  $j \in I_u$ . Other pairs of values for the two binary variables activate one of equations (2) - (4) to prevent overlap in one direction.

Layout design constraints are included to ensure that sections are placed within the boundaries of the base land area. Equations (5) and (6) force any equipment  $i$  to be placed within the boundaries of section  $t$  to which it belongs:

$$lt_t \geq x_i + \frac{l_i}{2} \quad \forall t, i \in I_t \quad (5)$$

$$dt_t \geq y_i + \frac{d_i}{2} \quad \forall t, i \in I_t \quad (6)$$

The mid-point coordinates of each section is defined by equations (7) and (8):

$$xt_t \geq \frac{lt_t}{2} \quad \forall t \quad (7)$$

$$yt_t \geq \frac{dt_t}{2} \quad \forall t \quad (8)$$

and each section is located within the boundaries of the base land area:

$$xt_t + lt_t \leq X^{max} \quad \forall t \quad (9)$$

$$yt_t + dt_t \leq Y^{max} \quad \forall t \quad (10)$$

The horizontal distances in the x- and y- directions between units  $i$  and  $j$  connected to each other (equations (S.18) and (S.19)) are rewritten for situations where the units belong to different production sections. As such, the additional distance between sections has to be included. This is described by equations

(11) and (12):

$$R_{ij} - L_{ij} = \left(xt_t - \frac{lt_t}{2} + x_i\right) - \left(xt_u - \frac{lt_u}{2} + x_j\right) \quad (11)$$

$$\forall i, j : f_{ij} = 1; u \geq t; i \in I_t; j \in I_u$$

$$A_{ij} - B_{ij} = \left(yt_t - \frac{dt_t}{2} + y_i\right) - \left(yt_u - \frac{dt_u}{2} + y_j\right) \quad (12)$$

$$\forall i, j : f_{ij} = 1; u \geq t; i \in I_t; j \in I_u$$

For cases where units  $i$  and  $j$  belong to the same section ( $u = t$ ), equations (11) and (12) reduce to equations (S.18) and (S.19).

Equipment floor constraints from Ekeh et al. [2] (equations (S.2) - (S.6)) are modified to equations (13) - (17) as follows:

$$N_{ij} \geq V_{ik} + V_{jk} - 1 \quad \forall i, j > i, k \quad (13)$$

The variable  $N_{ij}$  is defined by equation (13), with a value of 1 if equipment items  $i$  and  $j$  are assigned a same floor, and 0 otherwise.

In order to prevent the top floors in some sections from being empty, it is necessary to determine the total number of floors required by each section, as opposed to having a maximum number across sections:

$$S_{ik}^s \leq W'_{kt} \quad \forall t, i \in I_t \setminus MF, k \quad (14)$$

$$W'_{kt} \leq W'_{k-1,t} \quad \forall k > 1; t \quad (15)$$

Equation (14) ensures that for each section  $t$ , floor  $k$  will only exist if a non-multi-floor equipment  $i$  belonging to that section starts on it. For cases where only multi-floor equipment exists in a section  $t$ , an additional constraint is included for such equipment and its section of the same form as equation (14):

$$S_{ik}^s \leq W'_{kt} \quad \forall t : I_t \setminus MF = \emptyset, i \in I_t, k \quad (16)$$

Empty intermediate floors are eliminated by equation (15), and the total number of floors per section is obtained by equations (17) and (18) - less than or equal to the available number of floors, but just enough for any equipment that belongs to the section:

$$NF'_t \geq \sum_k W'_{kt} \quad \forall t \quad (17)$$

$$NF'_t = \sum_s NQ'_{st} \quad \forall t \quad (18)$$

Also, the maximum number of floors ( $NF^{max}$ ) across sections is calculated in order to determine the total fixed floor construction cost:

$$NF^{max} \geq NF'_t \quad \forall t \quad (19)$$

The objective function is then written to account for production sections and area-dependent floor construction cost for floors that exist in each section:

$$\sum_i \sum_{j \neq i: f_{ij}=1} [C_{ij}^c T D_{ij} + C_{ij}^v D_{ij} + C_{ij}^h (R_{ij} + L_{ij} + A_{ij} + B_{ij})] + FC1 \cdot NF^{max} + FC2 \sum_s \sum_t l_t \cdot dt_t \cdot NQ_{st} + LC \cdot FA \quad (20)$$

This results in a non-linear objective function which is neither convex nor concave, because of the term  $\sum_s \sum_t l_t \cdot dt_t \cdot NQ_{st}$ . The objective function is linearised by introducing the following constraints:

First, a new term  $FA'_t$  representing the area of a section  $t$  is introduced. The sum of the areas of all sections  $t$  should be less than or equal to the total base land area.

$$FA \geq \sum_t FA'_t \quad (21)$$

The area of each section  $t$  is selected from a predefined set of rectangular sizes:

$$FA'_t = \sum_s AR'_s \cdot Q'_{st} \quad \forall t \quad (22)$$

where  $Q'_{st}$  is a binary variable allowing for a unique selection of predefined rectangular areas  $s$  for each section  $t$ . Such area is calculated from the minimum length and breadth required by each section:

$$l_t \leq \sum_s \bar{X}_s \cdot Q'_{st} \quad \forall t \quad (23)$$

$$dt_t \leq \sum_s \bar{Y}_s \cdot Q'_{st} \quad \forall t \quad (24)$$

where  $\bar{X}_s$  and  $\bar{Y}_s$  are the dimensions of the pre-defined rectangular area sizes. The area of a floor  $k$  in section  $t$  should only have a non-zero value if it exists (i.e. a non-multi-floor equipment is assigned on or above it):

$$W'_{kt} \leq FA'_{kt} \quad \forall k, t \quad (25)$$

and the value of such area should be the maximum obtained amongst all floors  $k$  in section  $t$ :

$$FA'_t - BM'(1 - W'_{kt}) \leq FA'_{kt} \quad \forall k, t \quad (26)$$

To ensure only one area size is selected from the predefined set, the following equation is used:

$$\sum_s Q'_{st} = 1 \quad \forall t \quad (27)$$

and the objective function becomes:

$$\begin{aligned} \min \sum_i \sum_{j \neq i: f_{ij}=1} [C_{ij}^c T D_{ij} + C_{ij}^v D_{ij} + C_{ij}^h (R_{ij} + L_{ij} + A_{ij} + B_{ij})] \\ + FC1 \cdot NF^{max} + FC2 \sum_k \sum_t FA2'_{kt} + LC \cdot FA, \end{aligned} \quad (28)$$

subject to plant-wide constraints (1) - (12); section-wide constraints (13) - (19), (21) - (27), (S.1), (S.7) - (S.17), (S.20) - (S.25), (S.28), (S.29), (S.33) and (S.34). This constitutes an extension of Model A.1 in Ejeh et al. [2]. For **model A.2**, equations (S.10), (S.12) and (S.13) are replaced with equation (S.36); for **model A.3**, equations (S.9), (S.10) and (S.13) are replaced with (S.37).

### 3.2. Formulation B

In Formulation B, tall/multi-floor equipment is represented by single-floor pseudo units. The number of pseudo units is equivalent to the number of floors required by the multi-floor equipment represented, with subsequent pseudo units of a specific multi-floor equipment occupying the same position on successive floors. Extending the work of Ejeh et al. [2], equation (S.42) is modified to:

$$V_{i'k} \leq W'_{kt} \quad \forall t, i' \in I'_t \setminus \bigcup_{i \in MF} P_i, k \quad (29)$$

For situations where only pseudo-units of a multi-floor equipment exist in a section, equation (30) is included for the pseudo-units assigned to the lowest floor for each multi-floor equipment in such section:

$$V_{i'k} \leq W'_{kt} \quad \forall t: I'_t \setminus \bigcup_{i \in MF} P_i = \emptyset, i' \in I'_t \cap P^1, k \quad (30)$$

and the objective function becomes:

$$\begin{aligned} \min \sum_{i'} \sum_{j' \neq i': f_{i'j'}=1} [C_{i'j'}^c T D_{i'j'} + C_{i'j'}^v D_{i'j'} + C_{i'j'}^h (R_{i'j'} + L_{i'j'} + A_{i'j'} + B_{i'j'})] \\ + FC1 \cdot NF^{max} + FC2 \sum_k \sum_t FA2'_{kt} + LC \cdot FA, \end{aligned} \quad (31)$$

subject to plant-wide constraints (1) - (12); section-wide constraints (15), (17) - (19), (21) - (27), (29), (30), (S.7), (S.8), (S.14) - (S.17), (S.21) - (S.25), (S.28), (S.29), (S.33), (S.34), (S.38) - (S.41), and (S.45) - (S.49).

## 4. Case Studies

In this section, application of the proposed models to two case studies is shown. Each example was solved using GAMS v25.0.2 [11] and CPLEX v12.8.0.0

solver with a single thread of an Intel(R) Xeon(R) E5-1650 CPU with 32GB RAM. Each of the proposed models was solved to global optimality or a time limit of 10,000s. For the floor area, twelve alternative sizes (5m - 60m, with a step size of 5m) was used, giving a total of 144 possible area sizes. The plan of the optimal layout configuration is presented for model A.1 alone, while the layout configurations for models A.2, A.3 and B are available in the supplementary information.

#### 4.1. Example 1

Example 1 is a Crude Distillation (CDU) plant with preheating train, simulated with Aspen HYSYS® v8.0. It consists of 17 units, with 5 (atmospheric distillation tower (unit 7), vacuum distillation tower (unit 13), fired heaters 1 and 2 (unit 6 and 12), and debutaniser (unit 15)) exceeding the floor height of 5m. The process flow diagram of the plant is shown in Figure 1, and 7 floors are available for layout.

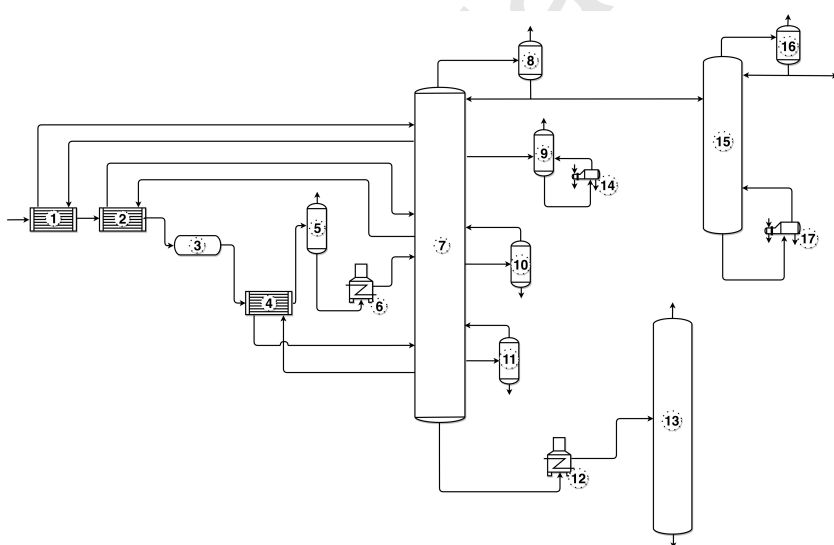

**Figure 1: Flow diagram of Crude Distillation Plant with Preheating train**

In this example, two production-section types are defined for investigation, due to different considerations. In the first, process units are assigned to sections based on the collective function performed (referred to as "function based") - crude oil preheating, crude oil heating, atmospheric distillation, atmospheric-bottoms heating, vacuum distillation, and debutanisation sections. As such, a total of six sections was realised. The second type assigned process units to sections based on the individual/common property of the unit (referred to as "unit based") - heat exchangers, separation equipment and fired heaters - giving

a total of three sections. The equipment dimensions, allocations to unit based and function based production sections, data on the connectivity and construction costs, and other parameters are available in the supplementary information. The CDU plant multi-floor layout problem is firstly solved without considering the above pre-defined production sections, as a base case for discussion using the models described in Appendix A with equations (S.2) and (S.3) replaced with equation (13). Particularly for the base case of this example, equation S.33 is modified to  $x_i + y_i - x_j - y_j \leq \delta \cdot N_{ij}$  for the same pair of  $i$  and  $j$  as originally defined. The results gave a total of five possible floors, out of an available seven with each floor measuring  $20.0 \times 15.0$ m. A total cost of 603,886.5 rmu was obtained across all formulations as seen in Table 1.

**Table 1: Summary of model statistics and computational performance for CDU Plant - no sections**

	CDU Plant (17 units)			
	A.1	A.2	A.3	B
Total cost (rmu)	603,886.5			
CPU (s)	1,884.9	2,791.3	2,079.2	10,000 (3.0%) <sup>1</sup>
Number of discrete variables	551	551	551	1,258
Number of continuous variables	793	674	793	906
Number of equations	2,365	2,145	2,127	11,574

<sup>1</sup>Relative gap quoted at CPU limit of 10,000s

The layout of equipment is shown in Figure 2. The optimal floor location and position for each equipment was determined by all models, with multi-floor equipment being assigned contiguous floors. It is worthy of note that although equipment 15 required 5 floors based on its height, it was assigned 3 floors (floors 3 -5) by all formulations. Here, the construction of a sixth and seventh floor was deemed unnecessary as no equipment other than equipment 15 was to be placed on such floor. This establishes that although multi-floor equipment can span contiguous floors, not all of such floors need to be constructed. This feature has practical applications with multi-floor layouts about fired heaters with long stacks, distillation columns and flare stacks.



**Figure 2: CDU Plant Layout results - no sections; with unit-based sections colour code**

For the layout of the base case, as no considerations were given for production sections, equipment of similar function or type were not placed in a common area. An example of this is illustrated in Figure 2 where the fired heaters for the CDU and VDU towers - 6 and 12 - belonging to the same unit-based section, were located amidst other equipment types. This inability of the previous models [2] to account for production sections could lead to reduced efficiency in plant activities, such as the scheduled maintenance of similar equipment based on type or function, or the overall control of process conditions within these groups of equipment. Also, the implementation of safety procedures unique to equipment type cannot be properly enforced in this layout. These can impact the overall safety levels in the plant. Each of these concerns can be mitigated with the inclusion of production section features.

The extended models were then applied for the function-based section consideration. The model statistics is shown in Table 2. A total cost of 765,742.7 rmu with a base land area of 40.0×15.0m was realised with models A outperforming B. The floor areas of sections 1 - 6 were 9.7×8.9m, 3.9×3.9m, 12.3×14.3m, 3.9×3.9m, 9.4×9.4m and 6.5×5.3m respectively. The models simultaneously handled the optimal layout within each section and amongst sections.



**Table 2: Summary of model statistics and computational performance for CDU Plant - Function based sectioning**

	CDU Plant - Function based sectioning (17 units, 6 sections)			
	A.1	A.2	A.3	B
Total cost (rmu)	765,742.7			
CPU (s)	197.7	104.5	245.0	465.3
Number of discrete variables	1,270	1,270	1,270	1,475
Number of continuous variables	1,586	1,467	1,586	1,699
Number of equations	2,042	1,822	1,804	10,247

Figure 3 shows a plan of the layout. All sections are located from the ground floor (floor 1) upwards, but certain sections (e.g. Section 5 in floors 2-5) do not need to be constructed on subsequent floors, as process units in such sections are non-existent. This saves cost in construction, as although the total land area boundary is depicted in the layout of each floor in the figures, sections only need to be constructed if equipment allocated to them exists in such floor. The choice can also be made for a full floor construction to provide additional space that can be allocated to other non-processing units in the process plant. All models obtained the same layout, save for orientation changes. In each of these layouts, it is observed that equipment of similar function are placed in the appropriate section, allowing for easier control of specific processes within the plant, and isolation of equipment/sections in the event of an accident.

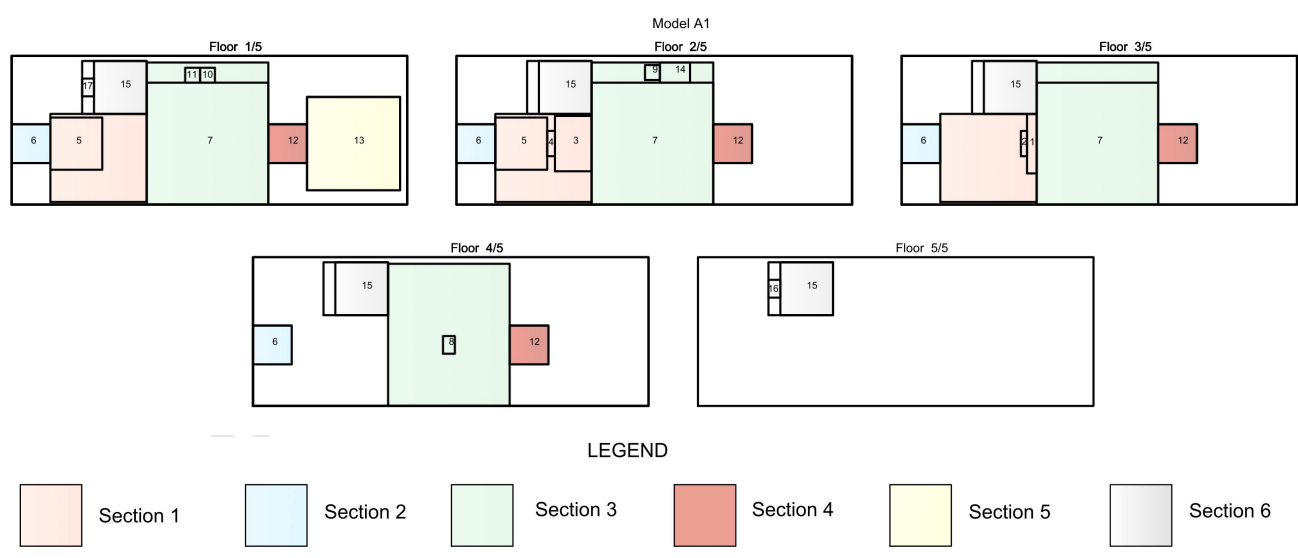

Figure 3: CDU plant - function based sectioning

The optimal layout of the unit based sections for the CDU plant is shown in Figure 4 (for model A.1) and in the supplementary information (for models A.2, A.3 and B), with the model performance in Table 3. A total cost of 684,828.7 rmu was determined; 13.4% more than the case without sections, but less than the function based sections earlier calculated. The total base land area was 20.0×20.0m, and areas of sections 1 - 3 were 1.6×10.0m, 17.9×14.3m, and 10.0×3.9m respectively. As only 3 sections were specified, space from additional sections in the function-based sectioning case is allocated to other process units, which reduces cost. Thus, it can be concluded for the CDU plant that the unit-based production section is more promising than the function-based, in terms of layout cost benefits.

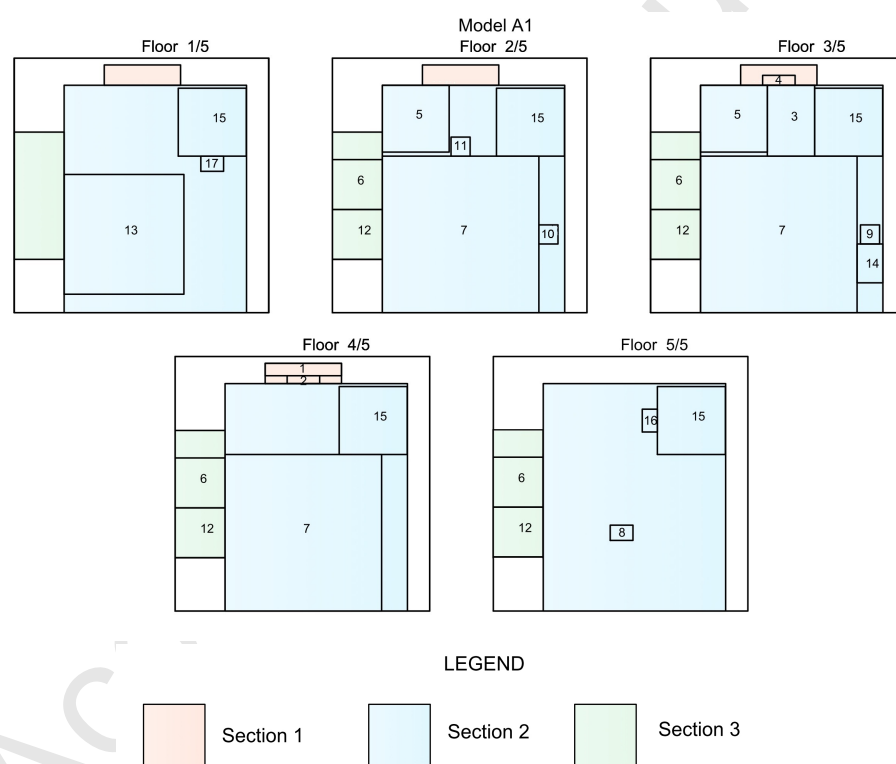
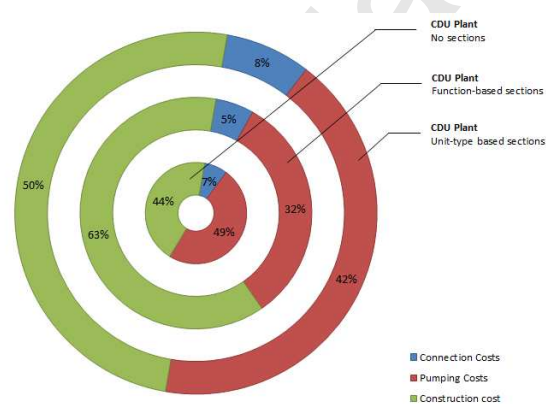

Figure 4: CDU plant - unit based sectioning

**Table 3: Summary of model statistics and computational performance for CDU Plant - unit based sectioning**

	CDU Plant - unit based sectioning (17 units, 3 sections)			
	A.1	A.2	A.3	B
Total cost (rmu)	684,828.7			
CPU (s)	149.0	65.2	170.4	5,843.9
Number of discrete variables	874	874	874	1,247
Number of continuous variables	1,118	999	1,118	1,231
Number of equations	2,069	1,849	1,831	10,610

Figure 5 shows the total cost distribution for all three cases, with construction having the larger portion of the costs. Construction costs for the function-based production section case is relative higher owing to the greater number of sections being considered.



**Figure 5: Total Cost Distribution CDU Plant**

#### 4.2. Example 2

Example 2 is a Liquefied Natural Gas liquefaction plant (LNG Plant) presented in [Hwang and Lee\[7\]](#). It consists of 22 units as shown in Figure 6 to be located on five decks of an LNG-FPSO topside with floor heights of 8m.

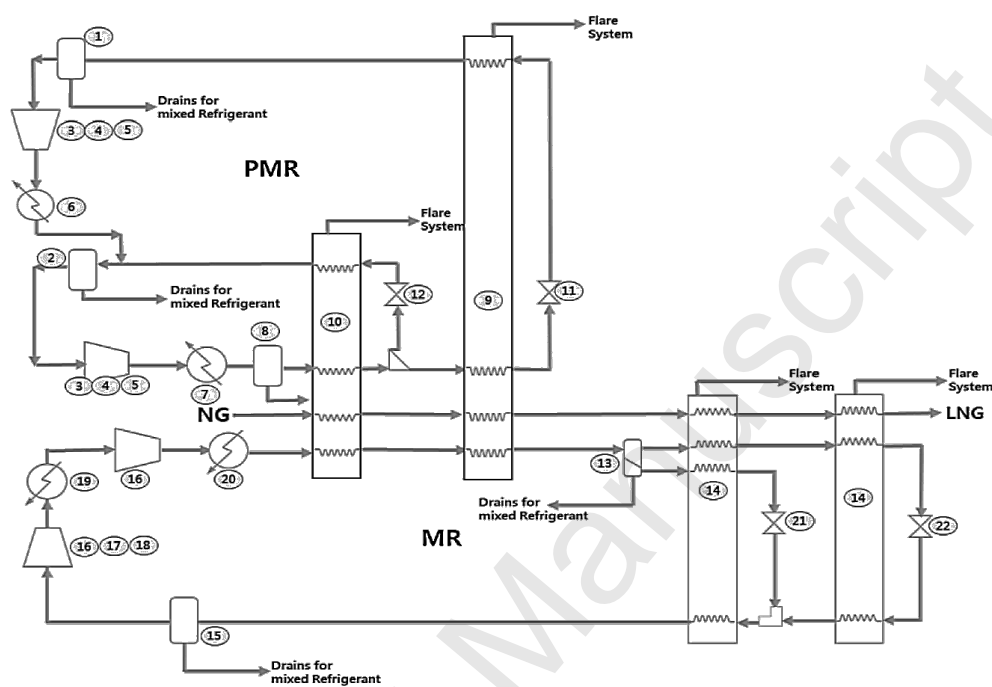

Figure 6: Flow diagram of LNG MR liquefaction cycle

Here, 3 production sections are incorporated - Pre-cooled Mixed Refrigerant (PMR) module 1, Pre-cooled Mixed Refrigerant (PMR) module 2, and the Mixed Refrigerant (MR) module. Equipment dimensions, production section allocation and data on the connectivity and construction costs are available in the supplementary information. The unique features of this case study are that the MR compressor (16) has to be located directly above the MR compressor cooler (17), and below the overhead crane (18); the PMR compressor (3) must be above its cooler (4) and below its overhead crane (5); the minimum distance between each equipment should be 4m; and, a workspace area of at least 50% and an emergency area of at least 60% on the ground and topmost floor respectively must be enforced. The following additional constraints are thus included:

$$V_{ik} = V_{j,k+1} \quad \forall (i, j) \in I_{E2} \quad (32)$$

$$x_i = x_j \quad \forall (i, j) \in I_{E2} \quad (33)$$

$$y_i = y_j \quad \forall (i, j) \in I_{E2} \quad (34)$$

$$FA - \left( \sum_i V_{i,1} \alpha_i \beta_i - 9 \cdot X^{max} \right) \geq 0.5FA \quad (35)$$

$$FA - \left( \sum_i V_{i,5} \alpha_i \beta_i - 9 \cdot X^{max} \right) \geq 0.6FA \quad (36)$$

where  $I_{E2} = \{(3, 5), (4, 3), (16, 18), (17, 16)\}$ . Equations (32) - (34) enforce the relative equipment positioning. Equations (35) and (36) are applied to each section and ensure that a portion of the area on the first and last floor is left free by at least 50% and 60% of the total floor area for the workspace and emergency area respectively. This total floor area is taken as the area available for equipment layout plus an additional free area of  $X^{max} \times 9m$  [7].

The example was firstly solved without production section considerations, and the solution is summarised in Table 4. Each of models A.1 - B did not obtain a globally optimal solution at the time limit of 10,000s. Model A.2 however, proved to be the most computationally efficient with a cost value of 1,466,654.2 rmu - with 4%, 35% and 61% attributed to connection, pumping and construction costs respectively. A floor area of  $30.0 \times 35.0m$  for 5 total floors was calculated.

**Table 4: Summary of model statistics and computational performance for LNG Plant - no sections**

	LNG Liquefaction (22 units)			
	A.1	A.2	A.3	B
Total cost (rmu)		1,466,654.2		1,563,086.2
CPU (s)		10,000		
	(3.7%) <sup>1</sup>	(2.4%) <sup>1</sup>	(3.7%) <sup>1</sup>	(26.0%) <sup>1</sup>
Number of discrete variables	732	732	732	1,398
Number of continuous variables	890	780	890	1,011
Number of equations	2,990	2,778	2,770	10,734

<sup>1</sup>Relative gap quoted at CPU limit of 10,000s

The layout plots in Figure 7 (and in the supplementary information) showed that all models were able to incorporate the additional considerations required in the example of relative equipment positioning, additional space provision (for emergency and maintenance activities at the desired floors) and minimum equipment spacing. Furthermore, model B, unlike models A.1 - A.3, can model cases of multi-floor equipment that have varying dimensions (length, breadth or diameter) at different floors, owing to an irregular shape (e.g. a Fluid Catalytic Cracking (FCC) unit) or the presence of varying amounts of process unit auxiliaries per floor.

It can also be observed from Figure 7 that equipment items are located irrespective of the function they perform. For example, the PMR LP suction drum (1) is well isolated from its compressor - 3 - and other equipment (2 - 7) in the PMR module 1. This can reduce the efficiency of maintenance activities for the PMR compressor, as well as process control operations for the PMR module 1.

Manuskript

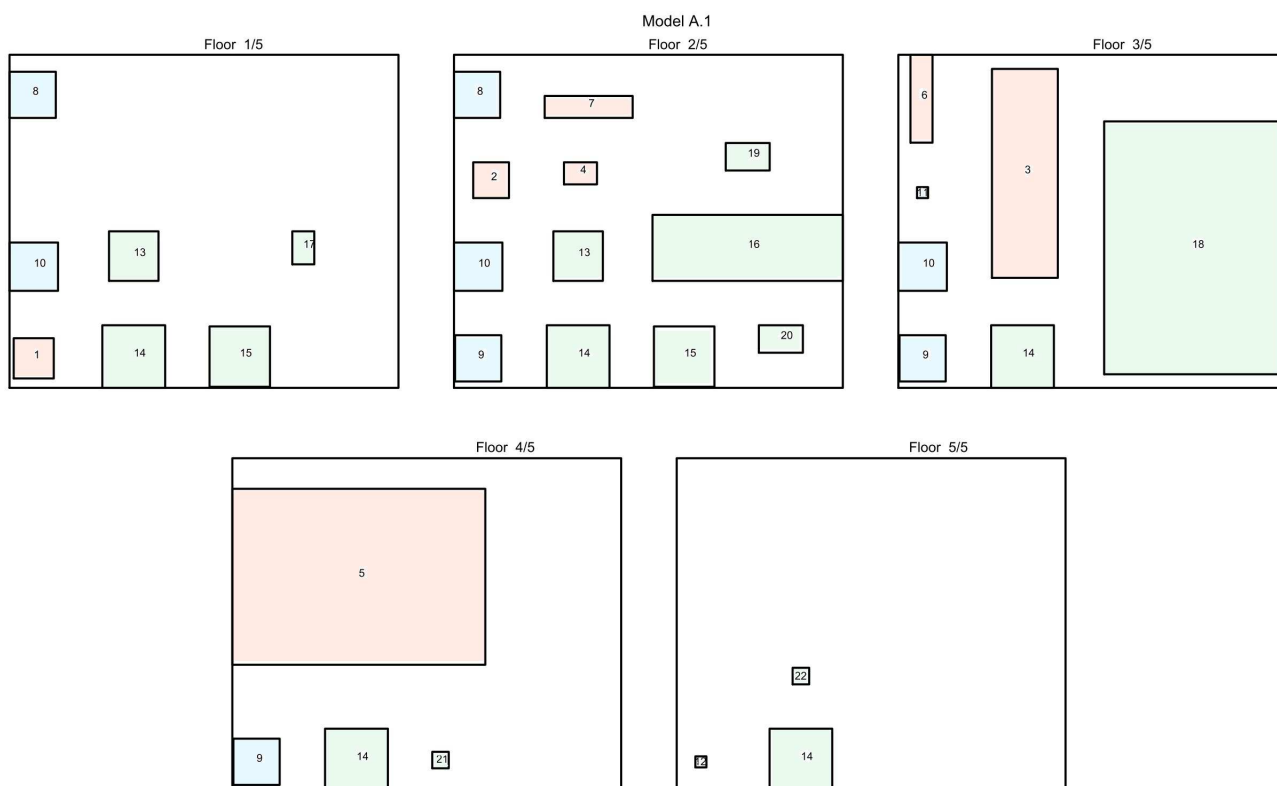

20

Figure 7: LNG Plant layout results - no sections

Considering the 3 production sections/modules, the statistics of the proposed models are shown in Table 5. A total cost of 1,690,372.9 rmu representing a 15% increase in comparison with its base case was obtained, with a base land area of 35.0×40.0m. However, layout results showed that floors 4 and 5 do not need to be constructed in the PMR Module 1. The PMR module 1 had a floor area of 22.8×18.9m, PMR module 2 - 4.4×17.5m and MR module - 33.4×17.1m. Models A solved in times below 15 minutes, achieving global optimality, while Model B, owing to the greater number of decision variables did not achieve global optimality by the time limit of 10,000 seconds.

**Table 5: Summary of model statistics and computational performance for LNG Plant with production sections**

	LNG Liquefaction with production sections (22 units)			
	A.1	A.2	A.3	B
Total cost (rmu)	1,690,372.9			
CPU (s)	683.1	883.2	700.2	10,000 (0.6%) <sup>1</sup>
Number of discrete variables	872	872	872	1,164
Number of continuous variables	1,209	1,099	1,209	1,330
Number of equations	2,312	2,100	2,092	9,308

<sup>1</sup>Relative gap quoted at CPU limit of 10,000s

The optimal layout is shown in Figure 8. Besides satisfying the minimum equipment spacing requirement and relative positioning, all models obtained layouts that allowed for well-defined production sections. These production sections occupy a common area over an optimal number of floors.





Figure 8: LNG Plant with production sections layout results

The total cost statistic is shown in Figure 9 for the layout with production sections. Construction costs are relatively higher due to additional space requirements for equipment segregations. This is observed in both examples investigated, where the total plant layout costs with production sections were higher than without them. However, due to other benefits in the areas of plant safety, operability, maintenance and workforce management, etc., having production sections with pre-defined equipment is still common practice for plant layout in the industry.

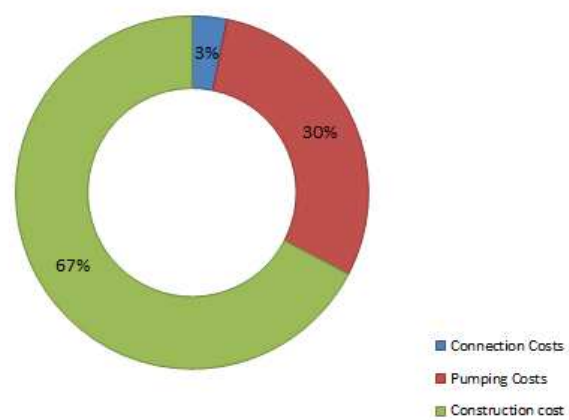

Figure 9: Total Cost Distribution (LNG Liquefaction plant with production sections)

## 5. Concluding remarks

An extension of the plant layout models by Ejehe et al. [2] was proposed to account for production sections in multi-floor chemical process plants having tall/multi-floor equipment. Additional constraints were included in all four models (A.1, A.2, A.3 and B) to account for equipment allocated to different production sections. These models simultaneously determined the optimal arrangement of production sections amongst one another (site layout), the arrangement of equipment in each production section (plot layout), as well as the number of floors per section, floor areas and total cost values considering pumping, connection, and construction costs.

Two case studies were presented to highlight model applicability and performance. Each case study was solved using the models in Ejehe et al. [2] as a base case (without production sections) and then with the proposed models. The results showed that in both cases, the feature of production sections cannot be achieved by the models in Ejehe et al. [2]. In the first case study - a CDU

plant - two criteria on production section allocation were adopted. For the first criterion, equipment was placed in production sections based on the collective function performed, and for the second, production sections were based on the individual properties of the equipment, with the second being more cost effective. In both cases, an increase in layout costs compared with the base case was realised due to increased space requirements for production sections. Also, most of the proposed models achieved global optimality well under 10 minutes. The second and larger case study - LNG liquefaction plant - with 22 units in 3 production sections also gave a higher cost with production sections. Models A reached global optimality under 15 minutes, with layout results giving an optimal number of floors per section.

From the case studies, it was observed that the optimisation models with production sections outperform the models without them in terms of computational efficiency. This, combined with the development of decomposition techniques may lead to more efficient solutions for larger case studies.

#### **Acknowledgement**

JOE gratefully acknowledges the Petroleum Technology Development Fund (PTDF), Nigeria.

#### Appendix A. Optimal Multi-floor process plant layout without production sections models

The four models proposed by Ejeih et al. [2] are presented as follows:

##### Nomenclature

Additional symbols used are defined as follows:

##### Parameters

$\alpha_i, \beta_i, \gamma_i$	dimensions of equipment item $i$
$IP_{ij}$	distance between the base and input point on item $j$ for the connection between items $i$ and $j$
$OP_{ij}$	distance between the base and output point on equipment $i$ for the connection between items $i$ and $j$

##### Integer variables

$NF$  number of floors

##### Binary variables

$E1_{ij}, E2_{ij}$	non-overlapping binary, a set of values which prevents equipment overlap in one direction in the x-y plane
$N'_{ijk}$	1 if items $i$ and $j$ are assigned to floor $k$ ; 0, otherwise
$O_i$	1 if length of item $i$ is equal to $\alpha_i$ ; 0, otherwise
$Q_s$	1 if rectangular area $s$ is selected for the layout; 0, otherwise
$S_{ik}^f$	1 if item $i$ terminates on floor $k$ ; 0, otherwise
$W_k$	1 if floor $k$ is occupied; 0, otherwise

##### Continuous variables

$AR_s$	predefined rectangular floor area $s$
$D_{ij}$	relative distance in z coordinates between items $i$ and $j$ , if $i$ is lower than $j$
$h_i$	height of item $i$
$NQ_s$	linearisation variable expressing the product of $NF$ and $Q_s$
$U_{ij}$	relative distance in z coordinates between items $i$ and $j$ , if $i$ is higher than $j$
$z_i$	relative coordinate on the z-axis of the geometrical centre of item $i$

### A.1. Model A.1

#### A.1.1. Floor constraints

$$\sum_k V_{ik} = M_i \quad \forall i \quad (\text{S.1})$$

$$N'_{ijk} \geq V_{ik} + V_{jk} - 1 \quad \forall i, j > i, k \quad (\text{S.2})$$

$$N_{ij} \geq N'_{ijk} \quad \forall i, j > i, k \quad (\text{S.3})$$

$$S_{ik}^s \leq W_k \quad \forall i, k \quad (\text{S.4})$$

$$W_k \leq W_{k-1} \quad \forall k > 1; \quad (\text{S.5})$$

$$NF \geq \sum_k W_k \quad \forall i \quad (\text{S.6})$$

#### A.1.2. Equipment orientation constraints

A 90° rotation of equipment orientation is allowed in the x-y plane.

$$l_i = \alpha_i O_i + \beta_i (1 - O_i) \quad \forall i \quad (\text{S.7})$$

$$d_i = \alpha_i + \beta_i - l_i \quad \forall i \quad (\text{S.8})$$

#### A.1.3. Multi-floor equipment constraints

Multi-floor equipment is modelled as follows:

$$-V_{ik} + V_{i,k-1} + S_{ik}^s \geq 0 \quad \forall i, k \quad (\text{S.9})$$

$$-V_{ik} + V_{i,k+1} + S_{ik}^f \geq 0 \quad \forall i, k \quad (\text{S.10})$$

$$\sum_k S_{ik}^s = 1 \quad \forall i \quad (\text{S.11})$$

$$\sum_k S_{ik}^f = 1 \quad \forall i \quad (\text{S.12})$$

$$\sum_{k=k'}^{k'+M_i-1} V_{ik'} \geq M_i \cdot S_{ik}^s \quad \forall i, k \quad (\text{S.13})$$

#### A.1.4. Non-overlapping constraints

To prevent two or more equipment items occupying the same space within a floor, the following constraints are introduced:

$$x_i - x_j + BM(1 - N_{ij} + E1_{ij} + E2_{ij}) \geq \frac{l_i + l_j}{2} + De_{ij}^{min} \quad \forall i, j > i \quad (\text{S.14})$$

$$x_j - x_i + BM(2 - N_{ij} - E1_{ij} + E2_{ij}) \geq \frac{l_i + l_j}{2} + De_{ij}^{min} \quad \forall i, j > i \quad (\text{S.15})$$

$$y_i - y_j + BM(2 - N_{ij} + E1_{ij} - E2_{ij}) \geq \frac{d_i + d_j}{2} + De_{ij}^{min} \quad \forall i, j > i \quad (\text{S.16})$$

$$y_j - y_i + BM(3 - N_{ij} - E1_{ij} - E2_{ij}) \geq \frac{d_i + d_j}{2} + De_{ij}^{min} \quad \forall i, j > i \quad (\text{S.17})$$

#### A.1.5. Distance constraints

Distance constraints determine the relative distances in the x and y coordinates between connected equipment.

$$R_{ij} - L_{ij} = x_i - x_j \quad \forall i, j : f_{ij} = 1 \quad (\text{S.18})$$

$$A_{ij} - B_{ij} = y_i - y_j \quad \forall i, j : f_{ij} = 1 \quad (\text{S.19})$$

$$U_{ij} - D_{ij} = FH \sum_k (k-1)(S_{ik}^s - S_{jk}^s) + OP_{ij} - IP_{ij} \quad \forall i, j : f_{ij} = 1 \quad (\text{S.20})$$

$$TD_{ij} = R_{ij} + L_{ij} + A_{ij} + B_{ij} + U_{ij} + D_{ij} \quad \forall i, j : f_{ij} = 1 \quad (\text{S.21})$$

#### A.1.6. Area Constraints

The area of each floor is as described by equations (S.22) - (S.27).

$$FA = \sum_s AR_s Q_s \quad (\text{S.22})$$

$$\sum_s Q_s = 1 \quad (\text{S.23})$$

The floor length and depth is selected from the chosen rectangular area size dimensions:

$$X^{max} = \sum_s \bar{X}_s Q_s \quad (\text{S.24})$$

$$Y^{max} = \sum_s \bar{Y}_s Q_s \quad (\text{S.25})$$

$$NQ_s \leq K \cdot Q_s \quad \forall s \quad (\text{S.26})$$

$$NF = \sum_s NQ_s \quad (\text{S.27})$$

#### A.1.7. Layout design constraints

Layout design constraints ensure that equipment items are placed within the boundaries of the floor area and start from the base of a floor.

$$x_i \geq \frac{l_i}{2} \quad \forall i \quad (\text{S.28})$$

$$y_i \geq \frac{d_i}{2} \quad \forall i \quad (\text{S.29})$$

$$x_i + \frac{l_i}{2} \leq X^{max} \quad \forall i \quad (\text{S.30})$$

$$y_i + \frac{d_i}{2} \leq Y^{max} \quad \forall i \quad (\text{S.31})$$

$$z_i = \frac{h_i}{2} \quad \forall i \quad (\text{S.32})$$

#### A.1.8. Symmetry breaking constraints

Symmetry breaking constraints are introduced as follows:

$$x_i + y_i - x_j - y_j \geq \delta \cdot N_{ij} \quad \forall (i, j) = \arg \max_{i, j \in MF} C_{ij}^c \quad (\text{S.33})$$

$$E1_{ij} = 0 \quad \forall (i, j) = \arg \max_{i, j \in MF} C_{ij}^c \quad (\text{S.34})$$

where  $\delta = \min\left(\frac{l_i}{2}, \frac{d_i}{2}\right) + \min\left(\frac{l_j}{2}, \frac{d_j}{2}\right)$ . These fix the relative position of  $i$  to  $j$ . Units  $i$  and  $j$  are chosen as the two multi-floor units having the highest connection costs.

#### A.1.9. Objective function

$$\begin{aligned} \min \sum_i \sum_{j \neq i: f_{ij}=1} [C_{ij}^c T D_{ij} + C_{ij}^v D_{ij} + C_{ij}^h (R_{ij} + L_{ij} + A_{ij} + B_{ij})] \\ + FC1 \cdot NF + FC2 \sum_s AR_s \cdot NQ_s + LC \cdot FA \end{aligned} \quad (\text{S.35})$$

subject to (S.1) - (S.34).

#### A.2. Model A.2

Model A.2 has the same formulation as A.1 with the exception that equations (S.10), (S.12) and (S.13) are replaced by (S.36) below:

$$\sum_{\theta=1}^{M_i-1} V_{i,k+\theta} \geq (M_i - 1) \cdot (V_{ik} - V_{i,k-1}) \quad \forall i, k \quad (\text{S.36})$$

### A.3. Model A.3

For Model A.3, equations (S.9), (S.10) and (S.13) in model A.1 are replaced by (S.37) below:

$$V_{ik} - V_{i,k-1} = S_{ik}^s - S_{i,k-1}^f \quad \forall i, k \quad (\text{S.37})$$

### A.4. Model B

#### A.4.1. Floor constraints

$$\sum_k V_{i'k} = 1 \quad \forall i' \quad (\text{S.38})$$

$$N_{i'j'} \geq V_{i'k} + V_{j'k} - 1 \quad \forall i', j' > i', k \quad (\text{S.39})$$

$$N_{i'j'} \leq 1 - V_{i'k} + V_{j'k} \quad \forall i', j' > i', k \quad (\text{S.40})$$

$$N_{i'j'} \leq 1 + V_{i'k} - V_{j'k} \quad \forall i', j' > i', k \quad (\text{S.41})$$

$$V_{i'k} \leq W_k \quad \forall i', k \quad (\text{S.42})$$

$$W_k \leq W_{k-1} \quad \forall k = 2, \dots, K \quad (\text{S.43})$$

$$NF \geq \sum_k W_k \quad (\text{S.44})$$

#### A.4.2. Multi-floor equipment constraint

$$V_{i'k} = V_{i'-1,k-1} \quad \forall i' \in P_i, k \quad (\text{S.45})$$

$$x_{i'} = x_{i'+1} \quad \forall i' \in P_i \quad (\text{S.46})$$

$$y_{i'} = y_{i'+1} \quad \forall i' \in P_i \quad (\text{S.47})$$

$$O_{i'} = O_{i'+1} \quad \forall i' \in P_i \quad (\text{S.48})$$

#### A.4.3. Distance constraints

$$U_{i'j'} - D_{i'j'} = FH \sum_k (k-1)(V_{i'k} - V_{j'k}) + OP_{i'j'} - IP_{i'j'} \quad \forall i', j' \in I' : f_{i'j'} = 1 \quad (\text{S.49})$$

#### A.4.4. Objective function

$$\begin{aligned} \min \sum_{i'} \sum_{j' \neq i' : f_{i'j'} = 1} [C_{i'j'}^c TD_{i'j'} + C_{i'j'}^v D_{i'j'} + C_{i'j'}^h (R_{i'j'} + L_{i'j'} + A_{i'j'} + B_{i'j'})] \\ + FC1.NF + FC2 \sum_s AR_s.NQ_s + LC.FA \end{aligned} \quad (\text{S.50})$$

subject to (S.7), (S.8), (S.14) - (S.19), (S.21) - (S.34) and (S.38) - (S.49).



## References

## References

- [1] Barbosa-Póvoa, A. P., Mateus, R., Novais, A. Q., 2002. Optimal 3D layout of industrial facilities. *International Journal of Production Research* 40 (7), 1669–1698.
- [2] Ejeh, J. O., Liu, S., Chalchooghi, M. M., Papageorgiou, L. G., 2018. An optimisation-based approach for process plant layout (under review).
- [3] Furuholmen, M., Glette, K., Hovin, M., Torresen, J., jul 2010. A Coevolutionary, Hyper Heuristic approach to the optimization of Three-dimensional Process Plant Layouts - A comparative study. *IEEE Congress on Evolutionary Computation*, 1–8.
- [4] Georgiadis, M., Macchietto, S., may 1997. Layout of process plants: A novel approach. *Computers & Chemical Engineering* 21, S337–S342.
- [5] Guirardello, R., Swaney, R. E., nov 2005. Optimization of process plant layout with pipe routing. *Computers & Chemical Engineering* 30 (1), 99–114.
- [6] Hosseini-Nasab, H., Fereidouni, S., Fatemi Ghomi, S. M. T., Fakhrzad, M. B., 2018. Classification of facility layout problems: a review study. *International Journal of Advanced Manufacturing Technology* 94 (1-4), 957–977.
- [7] Hwang, J., Lee, K. Y., 2014. Optimal liquefaction process cycle considering simplicity and efficiency for LNG FPSO at FEED stage. *Computers and Chemical Engineering* 63 (63), 1–33.
- [8] Kheirkhah, A., Navidi, H., Messi Bidgoli, M., 2015. Dynamic facility layout problem: a new bilevel formulation and some metaheuristic solution methods. *IEEE Transactions on Engineering Management* 62 (3), 396–410.
- [9] Ku, N., Jeong, S.-Y., Roh, M.-I., Shin, H.-K., Ha, S., Hong, J.-W., jun 2014. Layout Method of a FPSO (Floating, Production, Storage, and Off-Loading Unit) Using the Optimization Technique. In: *Volume 1B: Offshore Technology*. ASME, pp. 1–11.
- [10] Ku, N.-K., Hwang, J.-H., Lee, J.-C., Roh, M.-I., Lee, K.-Y., 2014. Optimal module layout for a generic offshore LNG liquefaction process of LNG-FPSO. *Ships and Offshore Structures* 9 (3), 311–332.
- [11] McCarl, B., Meeraus, A., Van der Eijk, P., Bussieck, M., Dirkse, S., Nellissen, F., 2017. *McCarl expanded gams user guide version 24.6*. GAMS Development, Washington, DC.
- [12] Mecklenburgh, J., 1985. *Process plant layout*, 2nd Edition. Longman, New York.

- [13] Medina-Herrera, N., Jiménez-Gutiérrez, A., Grossmann, I. E., 2014. A mathematical programming model for optimal layout considering quantitative risk analysis. *Computers and Chemical Engineering* 68, 165–181.
- [14] Moran, S., dec 2016. Engineering Practice Process Plant Layout - Becoming a Lost Art? *Chemical Engineering* 123 (12), 71–76.
- [15] Nabavi, S. R., Taghipour, A. H., Mohammadpour Gorji, A., 2016. Optimization of Facility Layout of Tank farms using Genetic Algorithm and Fireball Scenario. *Chemical Product and Process Modeling* 11 (2).
- [16] Navidi, H., Bashiri, M., Bidgoli, M. M., 2012. A heuristic approach on the facility layout problem based on game theory. *International Journal of Production Research* 50 (6), 1512–1527.
- [17] Papageorgiou, L. G., Rotstein, G. E., sep 1998. Continuous-domain mathematical models for optimal process plant layout. *Industrial & Engineering Chemistry Research* 5885 (9), 3631–3639.
- [18] Park, P. J., Lee, C. J., jun 2015. The Research of Optimal Plant Layout Optimization based on Particle Swarm Optimization for Ethylene Oxide Plant. *Journal of the Korean Society of Safety* 30 (3), 32–37.
- [19] Patsiatzis, D. I., Papageorgiou, L. G., 2002. Optimal multi-floor process plant layout. *Computers & Chemical Engineering* 26 (4), 575–583.
- [20] Patsiatzis, D. I., Papageorgiou, L. G., feb 2003. Efficient Solution Approaches for the Multifloor Process Plant Layout Problem. *Industrial & Engineering Chemistry Research* 42 (4), 811–824.
- [21] Penteado, F. D., Ciric, A. R., jan 1996. An MINLP Approach for Safe Process Plant Layout. *Industrial & Engineering Chemistry Research* 35 (4), 1354–1361.
- [22] Peters, M. S., Timmerhaus, K. D., 2003. *Plant Design and Economics for Chemical Engineers*. Vol. 4. McGraw-Hill New York.
- [23] Xin, P., Khan, F., Ahmed, S., jun 2016. Layout Optimization of a Floating Liquefied Natural Gas Facility Using Inherent Safety Principles. *Journal of Offshore Mechanics and Arctic Engineering* 138 (4), 041602.
- [24] Xu, G., Papageorgiou, L. G., 2009. Process plant layout using an improvement-type algorithm. *Chemical Engineering Research and Design* 87 (6), 780–788.