



Swansea University  
Prifysgol Abertawe



## Cronfa - Swansea University Open Access Repository

---

This is an author produced version of a paper published in :

*Proceedings of the 5th International Conference on Photonics, Optics and Laser Technology - Volume 1: PHOTOPTICS*

Cronfa URL for this paper:

<http://cronfa.swan.ac.uk/Record/cronfa31414>

---

### **Conference contribution :**

Ennsner, K. & Khamis, M. (2017). *Wide Broadband ASE Source based on Thulium-doped Fibre for 2 m Wavelength Region*. Proceedings of the 5th International Conference on Photonics, Optics and Laser Technology - Volume 1: PHOTOPTICS, (pp. 141-146). PHOTOPTICS 2017.

<http://dx.doi.org/10.5220/0006101801410146>

---

This article is brought to you by Swansea University. Any person downloading material is agreeing to abide by the terms of the repository licence. Authors are personally responsible for adhering to publisher restrictions or conditions. When uploading content they are required to comply with their publisher agreement and the SHERPA RoMEO database to judge whether or not it is copyright safe to add this version of the paper to this repository.

<http://www.swansea.ac.uk/iss/researchsupport/cronfa-support/>

# Wide broadband ASE source based on Thulium-doped fibre for 2 $\mu\text{m}$ wavelength region

M A Khamis and K Ennsner

*College of Engineering, Swansea University, Swansea, UK*  
[805172@swansea.ac.uk](mailto:805172@swansea.ac.uk), [k.ennsner@swansea.ac.uk](mailto:k.ennsner@swansea.ac.uk)

**Keywords:** Thulium-doped fibre; amplified spontaneous emission; silica glass material; Numerical modelling.

**Abstract:** This paper investigates the generation of the amplified spontaneous emission (ASE) from thulium-doped silica fiber pumped at 1570 nm. The developed model provides the ASE spectral power at short and long wavelength bands by using two different thulium doped fibre types with optimized fibre length. Shorter wavelengths in the emission band can be accessed with a short thulium fiber, whereas longer wavelengths can be obtained using a long thulium fiber. Our findings reveal that, in contrast to a 100 nm (1800nm-1900nm) and 70 nm (1900nm-1970nm) broadband source at short and long wavelength bands, a broader spectrum source can be achieved at about 170 nm (1800nm-1970nm) by a combined of the two ASE spectra via a wideband 50:50 coupler. As a result, the proposed ASE source configuration doubles the bandwidth of the conventional single fiber based light source.

## 1 INTRODUCTION

Over the last few years, broadband sources near 2  $\mu\text{m}$  have attracted the attention of many researchers. Hu et al. (2015) points out a broadband source at 2  $\mu\text{m}$  have many useful characteristics, including high output power, high light brightness, good beam quality, compact structure and excellent spatial coherence. These characteristics make broadband sources at 2  $\mu\text{m}$  suitable for use in a number of significant applications, such as remote sensing (Li et al. 2014), gas sensing (Hsu et al. 2008), medical surgery (Morse et al. 1995), materials processing (Jackson Sabella and Lancaster 2007) and atmospheric lidar measurement (Sugimoto et al., 1990). In addition, according to Halder et al. (2012) and Cheung et al. (2015), high power and wideband sources are required in optical coherence tomography and fiber optic gyroscopes.

One effective way to generate this broadband source is by using the process of amplified spontaneous emission between  ${}^3\text{F}_4$ - ${}^3\text{H}_6$  transition in thulium-doped fiber. High broadband source efficiency can be obtained via diode pumping on the

transition  ${}^3\text{H}_6 \rightarrow {}^3\text{H}_4$  in combination with high concentration of thulium-doped silica fiber in order to take into account the cross-relaxation process (Oh 1994; Shen et al. 2008). Alternatively, the need for high doping concentrations can be avoided by using an in-band pumping scheme, which directly excites the upper laser level on the transition  ${}^3\text{H}_6 \rightarrow {}^3\text{F}_4$ . Nevertheless, Tsang et al. (2005) explain that high efficiencies can be achieved because of the much lower quanta defect associated with this pumping scheme. However, in spite of the progress in the performance of thulium broadband sources the efficiency and bandwidth are still below those routinely provided from conventional thulium fiber laser oscillators.

To better optimize the broadband source performance near 2  $\mu\text{m}$ . It is necessary to develop a theoretical modeling and perform simulations. There are relatively few theoretical studies on ASE sources based on thulium-doped fiber (TDF) (Gorjan et al. 2012; Yu et al. 2010). On the other hand, various experimental configurations for broadening the spectral bandwidth of ASE source have been presented in the literature. Broader bandwidths up to

72 nm have been demonstrated using Tm: Ho-doped silica fibre (Tsang et al. 2005). Up to 100 nm of broadband spectra has been achieved using single end operation (Shen et al. 2008). However, these configurations have limited spectra bandwidth. This paper proposes a new thulium ASE configuration that doubles the bandwidth of the conventional configuration.

In this paper, a broadening ASE source can be generated from combining the ASE output source of two different TDFs as shown in fig.(1). The first fiber TDF<sub>1</sub> is a commercial thulium fibre (TmDF200 from OFS) with short fiber length. Agger and Povlsen (2006) demonstrated that the center emission spectrum of this fiber is at the wavelength 1800 nm. The second fiber TDF<sub>2</sub> is a commercial thulium fibre (SM-TSF-9/125 from Nufern) with long fiber length. Jackson (2009) shows that this fiber produces an emission spectrum with 1900 nm center wavelength. Long TDF leads to shift the output spectrum to ward long wavelength bands (Li et al. 2013). Thus, TDF<sub>1</sub> generated ASE1 source with short wavelength bands which is centered at 1840nm and TDF<sub>2</sub> produced ASE2 source with long wavelength bands which is centered at 1950nm. The two ASE sources were combined together into a single ASE source via wideband 50:50 coupler. This type of coupler is already applied to design a widely tunable thulium laser (Stevens and Legg 2015). Notes that in our simulation, we choose couplers and combiners have flatting coupling response over the wavelengths range in order to allow broadband ASE source.

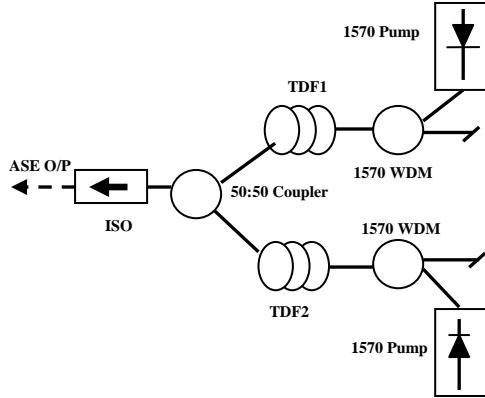

Figure 1. A schematic diagram of proposed ASE source. ISO is an optical isolator at 2 $\mu$ m, ASE o/p is the combined ASE sources of TDF<sub>1</sub> and TDF<sub>2</sub> ASE output. Note that all fibre ends are angle polished.

## 2 NUMERICAL MODEL OF ASE

A theoretical model of ASE generation are presented. The investigation into ASE spectral power is achieved by solving the rate and propagation equations. The model takes into account the wavelength-dependent absorption and emission cross-sections. Based on Jackson and King (1999) and including ASE, the rate equations of thulium energy levels are established as follows:

$$\frac{dN_2}{dt} = w_{p12}N_1(z,t) - w_{p21}N_2(z,t) - \frac{N_2}{\tau_2} - w_{s21}N_2(z,t) + w_{s12}N_1(z,t) \quad (1)$$

$$N_1(z,t) = N_T - N_2(z,t) \quad (2)$$

Here  $N_T$  is the Tm<sup>3+</sup> concentration and set to be a constant.  $\tau_2$  is the spontaneous lifetime of the <sup>3</sup>F<sub>4</sub> level  $N_1$  and  $N_2$  are the population densities of the <sup>3</sup>H<sub>6</sub> and <sup>3</sup>F<sub>4</sub> levels, respectively,  $w_{p12}$  is the pumping rate from <sup>3</sup>H<sub>6</sub> to <sup>3</sup>F<sub>4</sub> and  $w_{p21}$  represents the de-excitation of the <sup>3</sup>F<sub>4</sub> level;  $w_{s21}$  is the stimulated emission rate from <sup>3</sup>F<sub>4</sub> to <sup>3</sup>H<sub>6</sub>, and  $w_{s12}$  is the stimulated absorption rate from <sup>3</sup>H<sub>6</sub> to <sup>3</sup>F<sub>4</sub>. The expressions of  $w_{p12}$ ,  $w_{p21}$ ,  $w_{s21}$  and  $w_{s12}$  can be obtained from:

$$w_{p12} = \frac{\lambda_p \Gamma_p}{hcA_{core}} \sigma_a(\lambda_p) (p_p^-(z) + p_p^+(z)) \quad (3)$$

$$w_{p21} = \frac{\lambda_p \Gamma_p}{hcA_{core}} \sigma_e(\lambda_p) (p_p^-(z) + p_p^+(z)) \quad (4)$$

$$w_{s12} = \frac{\lambda_s \Gamma_s}{hcA_{core}} \sigma_a(\lambda_s) [ASE_f(z) + ASE_b(z)] \quad (5)$$

$$w_{s21} = \frac{\lambda_s \Gamma_s}{hcA_{core}} \sigma_e(\lambda_s) [ASE_f(z) + ASE_b(z)] \quad (6)$$

Here  $\lambda_p$  is the wavelength of the pump light and  $\lambda_s$  is the signal light in vacuum;  $h$  is the Planck constant;  $c$  is the light speed in vacuum;  $A_{core}$  is the cross-section area of the fibre core;  $\sigma_a(\lambda_p)$  and  $\sigma_a(\lambda_s)$  are the absorption cross-sections of the pump light and the signal light, respectively;  $\sigma_e(\lambda_p)$  and  $\sigma_e(\lambda_s)$  are the

emission cross-sections of the pump light and the signal light, respectively;  $P^\pm(z)$  is the pump (corresponding to forward and backward) at position  $z$ ; and  $ASE^+(z)$  and  $ASE^-(z)$  are the forward and backward amplified spontaneous emission powers at position  $z$ ;  $\Gamma_p$  and  $\Gamma_s$  are the confinement factors for the pump and the signal, respectively which are given by Eq. 7 (Whitley and Wyatt, 1993).

$$\Gamma(\lambda) = 1 - \exp\left(-\frac{2a^2}{w^2}\right) \quad (7)$$

Where  $w$  is the mode-width parameter of the fiber and  $a$  is the radius of the fiber. The normalized frequency  $V$  of the fiber is given by:

$$V = \frac{2\pi a NA}{\lambda} \quad (8)$$

As  $V > 1.5$  the mode-width parameter  $w$  of a step-index fibre can be determined by the normalized frequency  $V$  of the fiber as:

$$\frac{w}{a} = 0.632 + 1.478 V^{-3/2} + 4.76 V^{-6} \quad (9)$$

Meanwhile, the pump power distribution along the fiber length can be expressed by the following propagation equation:

$$\frac{dp_p^\pm}{dz} = \pm p_p^\pm(z) [\Gamma_p (\sigma_e(\lambda_p) N_2(z) - \sigma_a(\lambda_p) N_1(z)) - \alpha_p] \quad (10)$$

The positive sign in (10) relates to the forward direction and the negative sign to the reverse direction. The distribution of the ASE forward and backward powers along the fiber length can be established as follows (Hu et al., 2015; Yu et al., 2010):

$$\frac{dASE_f}{dz} = ASE_f(z) [\Gamma_s (\sigma_e(\lambda_s) N_2(z) - \sigma_a(\lambda_s) N_1(z)) - \alpha_s] + 2\sigma_e(\lambda_s) N_2(z) \frac{hc^2}{\lambda_s^3} \Delta\lambda \quad (11)$$

$$\frac{dASE_b}{dz} = -ASE_b(z) [\Gamma_s (\sigma_e(\lambda_s) N_2(z) - \sigma_a(\lambda_s) N_1(z)) - \alpha_s] - 2\sigma_e(\lambda_s) N_2(z) \frac{hc^2}{\lambda_s^3} \Delta\lambda \quad (12)$$

Where  $\alpha_p$  and  $\alpha_s$  are the intrinsic absorption at the pump and signal wavelength for the Thulium-doped

fibre, respectively,  $\Delta\lambda$  is the bandwidth of the amplified spontaneous emission (ASE) around  $2\mu\text{m}$ .

### 3 RESULTS AND DISCUSSION

To solve the thulium rate equations for the ASE model in steady state condition, the time derivatives of eq. (1) to (2) for in-band pumping are set to zero. The fourth-order Runge-Kutta method is applied to solve the differential equations of the pump and the amplified spontaneous emission ASE signals. Table 1 and 2 summarizes all parameters values used in the numerical simulations of the TDF<sub>1</sub> (Agger and Povlsen 2006) and TDF<sub>2</sub> (Jackson 2009), respectively. Initially, the entire population is assumed to be at the ground level  $^3\text{H}_6$  in the numerical calculations.

Table 1: Values of numerical parameters for TDF<sub>1</sub>

Symbol	Quantity	Value
$N_T$	Thulium concentration	$8.4 \times 10^{25} \text{ m}^{-3}$
$\tau_2$	Lifetime of level $^3\text{F}_4$	$650 \mu\text{s}$
$\lambda_p$	In-band pump wavelength	$1570 \text{ nm}$
$\sigma_a(\lambda_p)$	Laser absorption cross section at $1570 \text{ nm}$ .	$2.1 \times 10^{-25} \text{ m}^2$
$\sigma_e(\lambda_p)$	Laser emission cross section at $1570 \text{ nm}$ .	0
$\sigma_a(\lambda_s)$	Laser absorption cross section at signal wavelength	See (Agger and Povlsen, 2006)
$\sigma_e(\lambda_s)$	Laser emission cross section at signal wavelength	See (Agger and Povlsen, 2006)
NA	Numerical aperture	0.26
A	Area cross section of the core	$3.1 \times 10^{-11} \text{ m}^2$
$\alpha_p$	Intrinsic absorption at the pump wavelength	$1.07 \times 10^{-3} \text{ m}^{-1}$
$\alpha_s$	Intrinsic absorption at the signal wavelength	$1.15 \times 10^{-2} \text{ m}^{-1}$

Table 2: Values of numerical parameters for TDF<sub>2</sub>

Symbol	Quantity	Value
$N_T$	Thulium concentration	$1.37 \times 10^{25} \text{ m}^{-3}$
$\tau_2$	Lifetime of level $^3\text{F}_4$	$250 \mu\text{s}$
$\lambda_p$	In-band pump wavelength	$1570 \text{ nm}$
$\sigma_a(\lambda_p)$	Laser absorption cross section at $1570 \text{ nm}$ .	$2 \times 10^{-25} \text{ m}^2$
$\sigma_e(\lambda_p)$	Laser emission cross section at $1570 \text{ nm}$ .	0

$\sigma_a(\lambda_s)$	Laser absorption cross section at signal wavelength	See (Jackson 2009)
$\sigma_e(\lambda_s)$	Laser emission cross section at signal wavelength	See (Jackson 2009)
NA	Numerical aperture	0.15
A	Area cross section of the core	$6.36 \times 10^{-11} \text{ m}^2$
$\alpha_p$	Intrinsic absorption at the pump wavelength	$1.07 \times 10^{-3} \text{ m}^{-1}$
$\alpha_s$	Intrinsic absorption at the signal wavelength	$1.15 \times 10^{-2} \text{ m}^{-1}$

Table 3 explains the initial conditions for the pump power and the ASE spectrum in forward and backward directions. The thulium-doped fibre with length L is divided into N segments along the z-direction. The solution is applied for the pump and the ASE power propagating in the first segment (segment 0) by using the initial conditions in Table 3. For the following segments (segment 1 to N-1), the power for the pump and the ASE at one end of a segment is applied as the input for the next segment. Relaxation method is used to solve the differential equations of the pump and the ASE powers (Emami 2011). Using the data of Table 1, 2 and the values of the emission and the absorption cross-section, we solve numerically the rate equations of the pump and ASE power distribution.

Table 3: Initial conditions

Initial condition	Explanation
$P_p^+(z=0)$ = Forward launched pump power	Initial condition for 1558nm and 793nm pumps at $z=0$ .
$P_p^-(z=L)$ = Backward launched pump power	Initial condition for 1558nm and 793nm pumps at $z=L$ .
$P_s(z=0)$ = seed power	Initial condition for seed power at $z=0$ .
$ASE_f(z=0)=0$	Initial condition for forward amplified spontaneous emission at $z=0$ .
$ASE_b(z=L)=0$	Initial condition for backward amplified spontaneous emission at $z=L$ .

A MATLAB program is developed to evaluate the optimum thulium-doped fibre length for each of the two TDFs of fig. 1. Note that in our simulation the feedbacks of ends' reflection are set to zero and it is only applied forward pump configuration. Figure 2 and 3 illustrate the theoretical prediction of the output ASE forward power and the residual pump power for TDF<sub>1</sub> and TDF<sub>2</sub>, respectively. The launched pump power is equal 27dBm (0.55 W) at

case TDF<sub>1</sub> and 31.7dBm (1.5W) at TDF<sub>2</sub>. We clearly notice that the optimum fibre length of TDF<sub>1</sub> is 1.2 m at 1840nm output ASE as shown in fig. 2. In contrast to TDF<sub>2</sub>, the optimum fibre length is 5m at 1950nm output ASE as illustrated in fig. 3. In our configuration, 1.2m of TDF<sub>1</sub> is a suitable length to obtain short wavelength bands of ASE source which is centred at 1840nm, whereas 8m of TDF<sub>2</sub> is more suitable to access long wavelength bands which is centred at 1950nm.

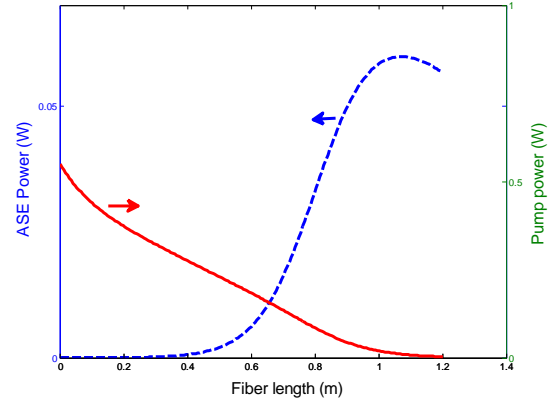

Fig. 2. Pump power distribution along TDF<sub>1</sub> length and the forward ASE at 1840nm when the launched pump power is 0.55W.

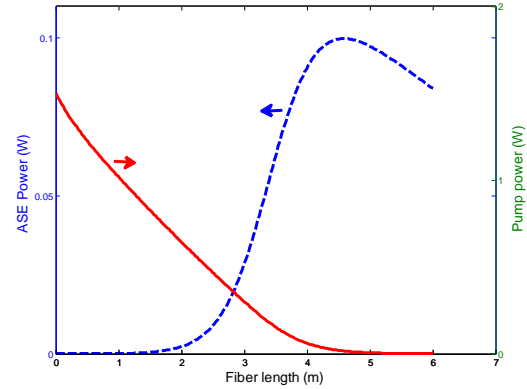

Fig. 3. Pump power distribution along TDF<sub>2</sub> length and the forward ASE at 1950nm when the launched pump power is 1.5W.

The next step is to investigate the output power spectra of ASE at short and long wavelength bands. Figure 4 shows the ASE spectrum of TDF<sub>1</sub> at 1.2m fiber length and 27dBm launched pump power. The bandwidths of forward ASE has full-width half maximums (FWHM) of approximately 100 nm between 1800nm and 1900nm compared to only

68nm and 88nm in forward and backward ASE obtained by Gorjan et al. (2012). The discrepancies are due to the difference in thulium fiber characteristics. Fig. 5 shows the ASE spectrum of TDF<sub>2</sub> at 8m fiber length and 31.7dBm is the launched pump power. The bandwidth of forward ASE at FWHM is approximately 70 nm between 1900nm and 1970nm. Finally, fig. 6 illustrates the combined ASE spectra of the TDF<sub>1</sub> and TDF<sub>2</sub> spectra. Notes that a wide 50:50 coupler is used and assumed to be flat over the range (1800nm-2000nm). It is clearly seen that the combined ASE provides approximately 170 nm bandwidth at FWHM between 1800nm and 1970nm. Thus, this is the first time to our knowledge that over 170nm bandwidth ASE source based only on thulium-doped fiber is reported.

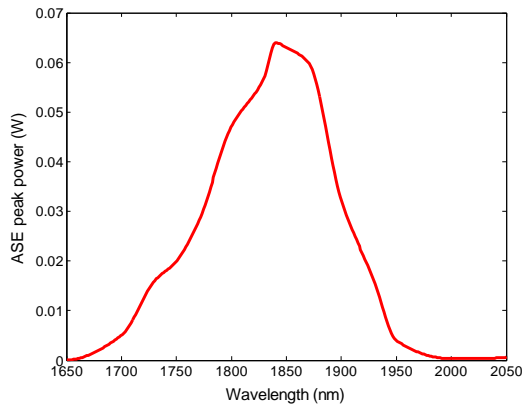

Figure 4: Power spectrum of the forward ASE at 1.2m of TDF<sub>1</sub> when 27dBm is the total input pump power.

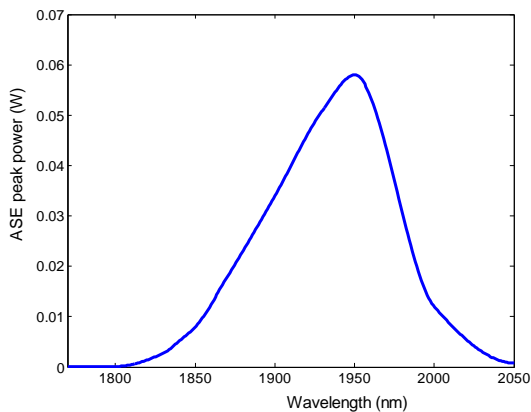

Figure 5: Power spectrum of the forward ASE at 8m of TDF<sub>2</sub> when 31.7dBm is the total input pump power.

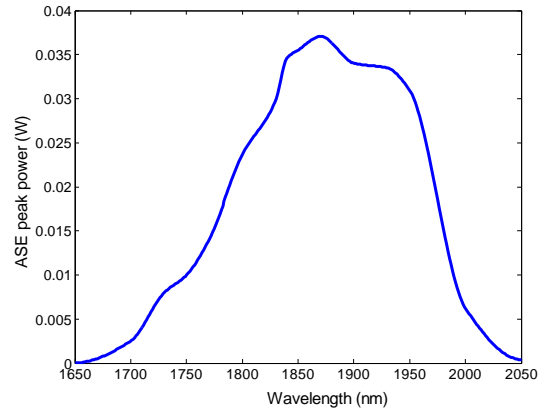

Figure 6: Combined power spectrum of the TDF<sub>1</sub> and TDF<sub>2</sub> ASE spectra by using flat wide 50:50 coupler.

## 4. CONCLUSION

A theoretical model of ASE generation around 2 $\mu$ m is built up by solving a set of rate and propagation equations. A MATLAB program is developed using the Runge-Kutta method to investigate the behaviour of the ASE generation at 2 $\mu$ m from two different thulium fibres types at 1570nm.

We chose two different fibre characteristics with optimised fibre length in order to generate ASE source for short and long wavelength bands. Wide band ASE source can be generated by combining the two wavelength bands. Thus, the main scope of this study is to generate broad band ASE source at 2  $\mu$ m for applications that require broader ASE bandwidth such as optical coherence tomography.

Our simulation results show that short wavelength bands (1800nm-1900nm) with 100nm FWHM bandwidth can be generated from the TDF<sub>1</sub>. In contrast to long wavelength bands (1900nm-1970nm) with 70nm FWHM bandwidth can be generated from TDF<sub>2</sub>. More than 170nm (1800nm-1970nm) should be produced from combining the two above ASE spectra. Note that we choose couplers and combiners have flattening coupling response over the wavelengths range in order to allow broadband ASE source. Hence, our suggested configuration is a suitable arrangement to obtain over 170nm wider broadband source at 2  $\mu$ m from thulium doped fibre.

## REFERENCES

- Hu, Z. et al. (2014). 'High power single stage thulium doped superfluorescent fiber source', *Appl. Phys. B.*, 118(1), pp. 101-107.
- Li, J. (2014). 'Wide wavelength selectable all-fiber thulium doped fiber laser between 1925 nm and 2200 nm', *Opt. Express*, 22( 5), pp. 5387-5399.
- Hsu, Z. C. et al. (2008). 'High power broadband all fiber super-fluorescent source with linear polarization and near diffraction-limited beam quality', *Proc. SPIE 7004*, 70044M .
- Morse, T. F., Oh, K. and Reinhart, L. J. (1995). 'Carbon dioxide detection using a co-doped Tm-Ho optical fiber', *Proc. SPIE*, 2510, pp.158-164.
- Jackson, S. D., Sabella, A. and Lancaster, D. G. (2007). 'Application and development of high-power and highly efficient silica-based fiber lasers operating at 2 $\mu$ m', *IEEE J. Sel. Top. Quantum Electron*, 13(3), pp. 567-572.
- Sugimoto, N., Sims, N. Chan, K. and Killinger, D. K. (1990). 'Eye-safe 2.1  $\mu$ m Ho lidar for measuring atmospheric density profiles', *Opt. Lett.*, 15, pp. 302-304.
- Halder, A. et al (2012). 'Wideband Spectrum-Sliced ASE Source Operating at 1900-nm Region Based on a Double-Clad Ytterbium-Sensitized Thulium-Doped Fiber', *IEEE Photonics J.*, 4(1), pp. 14-18.
- Cheung, C. S. et al. (2015), 'High resolution Fourier domain optical coherence tomography in the 2  $\mu$ m wavelength range using a broadband supercontinuum source', *Opt. Express*, 23(3), pp. 1992-2001.
- Oh, K. et al. (1994). 'Broadband superfluorescent emission of the  $^3H_4 - ^3H_6$  transition in a Tm-doped multicomponent silicate fiber', *Opt. Lett.*, 19, pp. 1131-1133.
- Shen, D. Y. et al. (2008). 'Broadband Tm-doped superfluorescent fiber source with 11 W single-ended output power', *Opt. Express*, 16(15), pp. 11021-11026.
- Tsang, Y., El-Sherif, H. A., and King, T. A. (2005). 'Broadband amplified spontaneous emission fiber source near 2 $\mu$ m using resonant in-band pumping', *J. Mod. Opt.* 52, pp. 109-118.
- Gorjan, M., North T. and Rochette, M. 2012. Model of the amplified spontaneous emission generation in thulium-doped silica fibers, *J. Opt. Soc. Am. B.*, 29, 2886.
- Yu, G. et al. (2010). 'A theoretical model of thulium-doped silica fiber's ASE in the 1900 nm waveband', *Optoelectron. Lett.* 6(1), 45-47.
- Agger, S. D. & Povlsen, J. H. (2006). 'Emission and absorption cross section of thulium doped silica fibers', *Optics express*, 14(1), pp. 50-57.
- Jackson, S. D. (2009). 'The spectroscopic and energy transfer characteristics of the rare earth ions used for silicate glass fibre lasers operating in the shortwave infrared', *Laser Photon. Rev.*, 3(5), pp. 466-482.
- Li, Z. et al. (2013). 'Diode-pumped wideband thulium-doped fiber amplifiers for optical communications in the 1800 – 2050 nm window', *Optics Express*, 21(22), pp. 26450-26455.
- Stevens, G., Legg, T. & Way, B. (2015). 'All-fibre widely tunable thulium laser', *Proc. SPIE 9728, Fiber Laser XIII*, 972814.
- Jackson, S. D. and King, T. A. (1999). 'Theoretical modeling of Tm-doped silica fiber lasers', *Journal of Lightwave Technology*, 17(5), pp. 948-956.
- Whitley T. J. and Wyatt R. (1993). 'Alternative Gaussian spot size polynomial for use with doped fiber amplifiers', *IEEE Photon. Technol. Lett.* 5(11), pp. 1325-1327.
- Emami, S. D. (2011). 'Thulium-Doped Fiber Amplifier, Numerical and Experimental Approach', Nova Science Publishers, Inc.