



Swansea University
Prifysgol Abertawe



Cronfa - Swansea University Open Access Repository

This is an author produced version of a paper published in :
Optics Communications

Cronfa URL for this paper:
<http://cronfa.swan.ac.uk/Record/cronfa30609>

Paper:

Khamis, M. & Ennser, K. (2017). Gain variation induced by power transient in thulium-doped fiber amplifier at 2 μ m and its reduction by optical gain clamping technique. *Optics Communications*, 384, 89-92.
<http://dx.doi.org/10.1016/j.optcom.2016.10.016>

This article is brought to you by Swansea University. Any person downloading material is agreeing to abide by the terms of the repository licence. Authors are personally responsible for adhering to publisher restrictions or conditions. When uploading content they are required to comply with their publisher agreement and the SHERPA RoMEO database to judge whether or not it is copyright safe to add this version of the paper to this repository.
<http://www.swansea.ac.uk/iss/researchsupport/cronfa-support/>

Gain variation induced by power transient in thulium-doped fiber amplifier at 2 μm and its reduction by optical gain clamping technique

M A Khamis^{*}, K. Ennsner

Electronic and Electrical Engineering, Swansea University, Swansea, UK.

Abstract

This paper investigates the dynamic behavior of a thulium doped fiber amplifier (TDFA) operating in the 2 μm region for reconfigurable wavelength division multiplexing (WDM) systems. We show deleterious channel power fluctuations may be generated by input power variation at the amplifier and we propose the use of an optical gain-clamping technique. The investigated system consists of 20 channels with -4 dBm total input power. Our findings revealed that the effects of power transients due to channel reconfigurations are significantly reduced by a lasing feedback signal. Simulation results show that a power excursion of 4.3 dB is produced after dropping 19 channels when the amplifier gain is unclamped and only 0.0062 dB when the amplifier gain is clamped. The dynamics of GC-TDFA are mainly influenced by the value of the pump power factor and thus the laser signal achieves a stronger stabilization condition with increasing pump power factor. Hence, optical gain clamping is a simple and robust technique to control the power transient in the thulium-doped fiber amplifier of WDM systems at 2 μm .

Keywords: Thulium-doped fiber amplifier, power transient, gain control, optical fiber communication.

1. Introduction

Over the past few decades, telecommunication networks are rapidly being driven toward the exponentially increasing capacity of internet traffic. The quests for increasing transmission capacity have motivated interest in radical new approaches to data transmission [1]. The region of 2 μm wavelength is attracting growing attention as a potential new window of data transmission for several reasons. First, hollow-core photonic band-gap fibers are a new form of transmission medium, which offer low loss window at 2 μm [2, 3]. In addition, thulium-doped fiber amplifiers (TDFAs) have recently been characterized and developed for optical communications, indicating low noise amplification and high gain in this spectral region [4]. Furthermore, the emission spectrum of the ${}^3\text{F}_4 - {}^3\text{H}_6$ transition in TDFA covers about 30 THz (1700-2100 nm) of amplification bandwidth in a single device more than two times that of the erbium-doped fiber amplifier (EDFA) with the same configuration and complexity [5].

To exploit the large amplifier bandwidth, WDM technology can be used. However, due to channel addition or dropping in dynamic optical WDM networks, the input power in the amplifier varies with time and it may cause gain transients in the optical amplifier [6-8]. As a result, gain variations lead to an increase in power excursion, which is defined as the ratio of maximum power to minimum power of the surviving channel. The TDFA dynamics restrict the distance of WDM transmission and

could cause problematic transients in communication networks at 2 μm [1]. When considering optical burst switching network, the input power variations can produce burst distortions. Power variations influence the gain of the optical amplifier when it operates in the saturation region. These variations in the amplifier gain lead to dynamic power fluctuations of surviving burst channels [9]. As a result, the signal-to-noise ratio of the received channels degrades. This problem accumulates when using cascade optical amplifiers [10]. Thus, the future of WDM in optical communication networks needs to provide control of dynamic amplifier gain variation.

To reduce this effect, several methods have been developed [11-16]. A simple and robust method is to clamp the amplifier gain via a lasing feedback signal. This method has been initially proposed and investigated for erbium-doped amplifiers in the 1550 nm region [11-14]. Later it has been experimentally demonstrated for TDFA in S-band [15], which has achieved a gain variation of 1.2 dB for input dynamic range from -21 to -6 dBm. However, no comprehensive investigation of gain-clamped TDFA for a new transmission window at 2 μm has been done yet. In this paper the theoretical model of gain-clamped scheme for TDFA in WDM reconfiguration network is presented. The proposed model is based on a laser configuration. The numerical investigations evaluate effects of the pump power in both power excursion and oscillation time.

^{*} Corresponding author. Tel: +00-000-000-0000; fax: +00-000-000-0000; E-mail: author@domain.com

2. Gain clamped TDFA modelling

Our model is based on the dynamic model expressed in a laser point of view at two-level system. This model describes the dynamic behavior of laser transition and already applied in Erbium-doped fiber amplifier to investigate the optical gain clamping [17]. According to theoretical models [18-21], thulium doped fiber transitions also behave as two energy levels when pumped at 1.558 μm . Thus in our case, we can apply this dynamic model to thulium doped fiber amplifier in order to study the dynamic behavior at add/drop channels of WDM systems. The rate equations of TDFA are given by:

$$\frac{dN_2}{dt} = -\frac{N_2}{\tau_T} - \frac{1}{V} [F_s(t)(G_s(t)-1)] \quad (1)$$

$$-\frac{1}{V} [F_p(t)(G_p(t)-1)]$$

$$N_0 = N_2 + N_1 \quad (2)$$

Where N_0 is the ion concentration of thulium, N_1 and N_2 are the ions concentration of levels $^3\text{H}_6$ and $^3\text{F}_4$, respectively, V is the active volume, τ_T is the fluorescence time of $^3\text{F}_4$ energy level, G_s is the signal gain, and G_p is the pump gain, which are given by Eq. (3) and (4), respectively:

$$G_p = e^{\Gamma_p L (\sigma_{ep} N_2 - \sigma_{ap} N_1)} \quad (3)$$

$$G_s = e^{\Gamma_s L (\sigma_{es} N_2 - \sigma_{as} N_1)} \quad (4)$$

Where Γ_p and Γ_s are the overlapping factors of the pump and signal wavelength, σ_{ap} and σ_{as} represent the absorption cross-section of the pump and the signal wavelength, and σ_{ep} and σ_{es} represent the emission cross-section of the pump and the signal wavelength. Also, L is the length of the thulium-doped fiber and A_{eff} is the effective area of the thulium fiber core. In Eq. (1), F_s and F_p are the laser and the pump flux, respectively. The pump flux can be related to the laser threshold as follows:

$$F_p(t) = x(t) F_{p,th} \quad (5)$$

Note that the factor x is set to unity for unclamped amplifier and greater than a unity for the clamped case. $F_{p,th}$ is the pump flux at laser threshold, which is given by:

$$F_{p,th} = \frac{\frac{N_2}{\tau_T} + \frac{1}{A_{\text{eff}} L} F_s (G_s - 1)}{(1 - G_p) A_{\text{eff}} L} \quad (6)$$

The OGC-TDFA design consists of two couplers, one narrowband filter, one variable attenuator (VA) and the thulium amplifier, which are connected together in a closed-loop configuration as shown in fig. 1. The lasing feedback signal builds up in the ring cavity, which forms a laser system. The rate equations for the laser systems, i.e., the optically clamped TDFA, including input channels as a perturbation are as follows:

$$\frac{dN_2}{dt} = -\frac{N_2}{\tau_T} - \frac{1}{V} [F_s(t)(G_s(t)-1)] \quad (7)$$

$$-\frac{1}{V} [F_p(t)(G_p(t)-1)] - \frac{1}{V} [F_L(t)(G_L(t)-1)]$$

$$\frac{dF_L}{dt} = \frac{F_L(t)(G_L(t)\alpha_L - 1)}{T} \quad (8)$$

Where F_L , G_L represent laser flux and gain, respectively, T is the round-trip time in the lasing cavity and α_L is the loss of laser cavity. It is seen from the above models that add/drop channels can be described as negative pump power fluctuations because the thulium inversion decreases since signal photons are amplified.

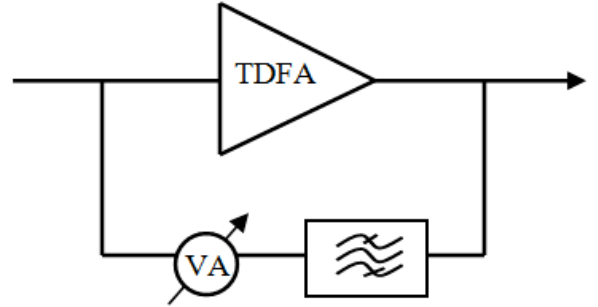

Fig. 1. Thulium doped-fiber amplifier in ring laser configuration.

3. Results and discussion

A MATLAB program is developed to study the dynamic behavior of the TDFA. It is assumed that the total input power is -4 dBm for 20 channels and each channel power being -17 dBm. To focus on the dynamics the channels are fixed at 1950 nm and the total power is varied according to the number of dropped or added channels as in [1]. In our simulations, we chose a commercial thulium fiber (TmDF200 from OFS) as an active fiber which was experimentally tested at [1,4] and offer good amplification characteristics such as high amplifier gain, broad bandwidth and low amplification noise. This fiber is co-doped with alumina that reduces the effect of concentration quenching and also enhances the fluorescence time of $^3\text{F}_4$ energy level.

The spectroscopy parameters of this fiber and our model are as follow [19,22]: $\lambda_p=1558$ nm, surviving channel (λ_s)=1950 nm, laser wavelength (λ_L)=1930 nm, $\Gamma_p=\Gamma_s=0.7$, $\tau_T=650$ μ s, $N_0=8.4\times 10^{25}$ m⁻³, $L=4$ m and $A_{eff}=3\times 10^{-11}$ m², finally the absorption and the emission cross-section of the pump, the signal, and the laser wavelength are taken from [22] and as follow: $\sigma_{ap}=2\times 10^{-25}$ m², $\sigma_{as}=0$, $\sigma_{ep}=0$ and $\sigma_{es}=2.1\times 10^{-25}$ m². Note that the calculated pump power at threshold for all below cases equals 22.75 dBm.

3.1 Impact of pump power level

The pump power level, defined by the factor x , is the main parameter that affects the dynamic performance of the gain-clamped amplifier. Figures 2 and 3 show the effect of the pump power factor in both oscillation time and power excursion of the surviving channel for a drop of 19 out of 20 channels. Here, the oscillation time is defined as a time when the surviving channel power reaches the saturation value.

It is seen that by increasing the value of the pump power factor, both power excursion and oscillation time reduce due to increase in the pump power making the laser signal reach stability earlier. However, increasing the power factor means increasing the pump power. For the purpose of studying the dynamics we assume $x = 1.3$.

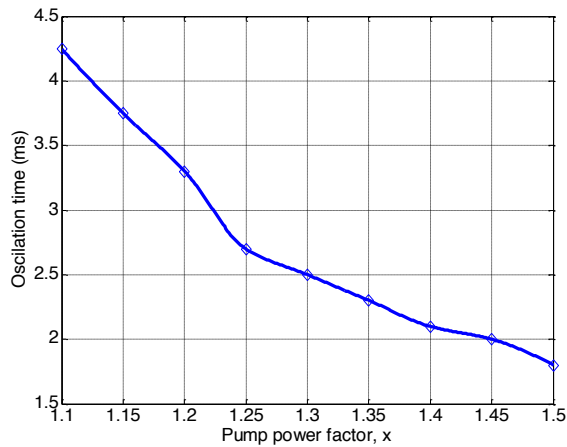

Fig. 2. Oscillation time of the surviving channel versus the pump power factor for dropping 19 out of 20 channels.

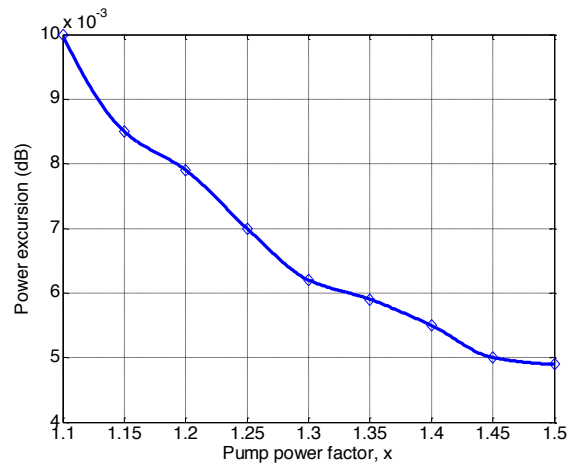

Fig. 3. Variation of the power excursion of the surviving channel versus the pump power factor for dropping 19 out of 20 channels.

3.2 Channel power oscillation after a perturbation

The next investigation is to study the power-oscillation dynamics after a perturbation. In our study, a perturbation refers to a change in the number of channels being amplified. The power-excursion variation when 19 out of 20 channels are dropped is shown for a clamped gain amplifier in fig. 4 and for an unclamped gain amplifier in fig. 5. It is clearly seen that a peak value of the surviving channel power excursion is 4.3 dB for the unclamped gain amplifier. As for the clamped gain case, the power excursion is restricted to only 0.0062 dB.

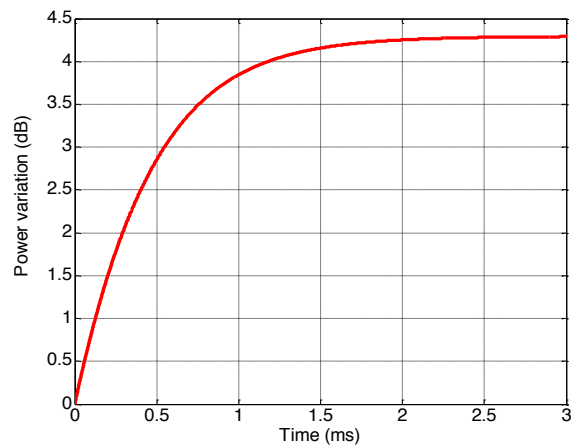

Fig. 4. Output power variation of the surviving channel for dropping 19 out of 20 channels at unclamped amplifier

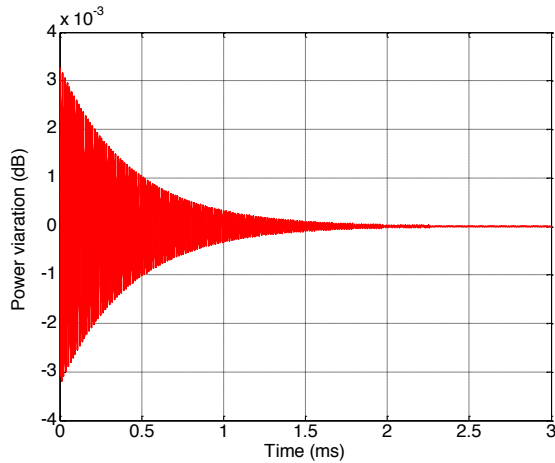

Fig. 5. Output power variation of the surviving channel for dropping 19 out of 20 channels at gain clamped amplifier.

Our result for unclamped amplifier is consistent with the experimental findings of a previous study [1]. The value of power excursion at unclamped gain is approximately the same with a small variation due to a few unknown parameters of TDFA used in [1]. The results from both studies confirm the gain dynamic characteristics of an unclamped TDFA and the considerable influence of drop channels on the power excursion of the surviving channel.

In comparison to typical EDFA in the C-band the power excursions in TDFA are smaller due to different characteristics of thulium fiber parameters. In addition, the required thulium-doped fiber length is shorter due to high thulium ions concentration and this will stabilize the OGC-TDFA quicker. A short feedback loop length (laser cavity) offers fast transient recovery time due to short photon cavity lifetime as an erbium doped waveguide amplifier (EDWA) [17]. Furthermore, the measure spectral hole burning SHB in TDFA at room temperature is lower than four times in EDFA [23] and consequently it has smaller SHB depth. These characteristics make the OGC technique more efficient when applied to TDFA.

3.3 Power excursion for Add/Drop channels

Figure 6 illustrates the output power excursion values for two different channel drop conditions. For a drop of 19 out of 20 channels, the maximum power excursion and the oscillation time of the surviving channel are about 0.0062 dB and 2.5 ms, respectively, when compared with 0.0005 dB and 1.75 ms for a drop of 2 out of 20 channels.

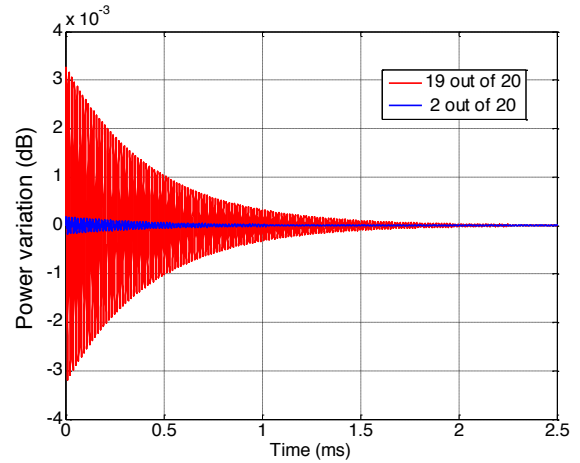

Fig. 6. Output power variation of the surviving channel after dropping 19 and 2 out of 20 of channels in GC-TDFA ($x=1.3$).

Figure 7 shows the power excursion after adding 4 and 6 channels in the 20 channels WDM system. The maximum power excursions are 0.02 dB and 0.044 dB after adding 4 and 6 channels, respectively. Because of the operating principle of GC-TDFA in the saturation regime, any adding channels to the WDM system leads to increase in the input signal power and possibly decrease in the gain. Hence, the power excursion increases with increasing number of channels that are added for the reason that the laser has a weaker stabilization condition when it is perturbed, as apparent in Fig. 7. In addition, the oscillation time in the case of channel addition is longer than in the case of channel dropping due to the output power is higher, and therefore operating in a higher slope point of the gain curve. Furthermore, the relaxation oscillation frequency is inversely proportional to the ratio of maximum power excursion and the amount of power added or dropped in the system. In other words, the larger the number of channels added or dropped in a system, the smaller is the oscillation frequency [24].

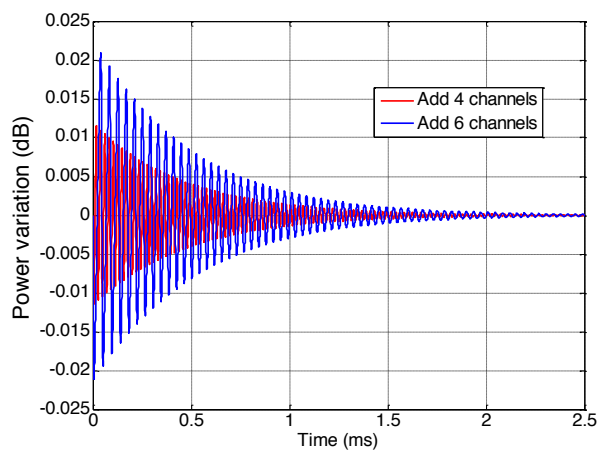

Fig. 7. Output power variation of the surviving channel in OGC-TDFA after an addition of 4 and 6 channels to the 20 channels ($x=1.3$).

In case more input power is added to the system, the pump power factor may not stabilize the optical amplifier and a larger value needs to be considered. To verify this, 8 channels are added to the 20-channel system for $x=1.3$ and $x=1.4$. From the data in fig. 8, it is shown that the pump power factor of 1.3 is insufficient to stabilize the optical amplifier because of the higher slope in the gain-saturation regime as the input power increases and therefore the system is more unstable and requires a stronger laser signal and consequently a higher pump factor.

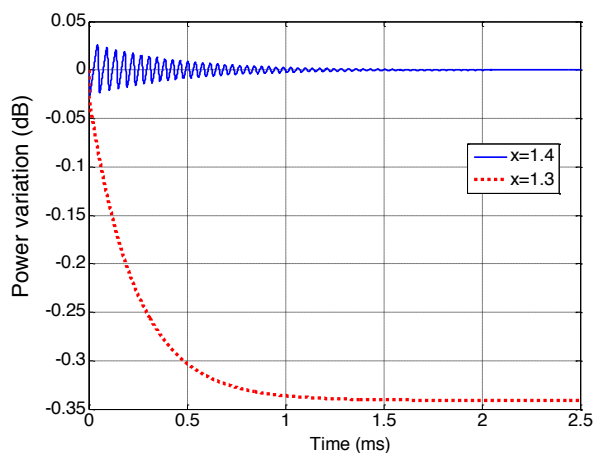

Fig. 8. Output power variation of the surviving channel in OGC-TDFA after an addition of 8 channels to the 20 channels ($x=1.3$ and 1.4).

4. Conclusion

In summary, a theoretical study of gain-clamped TDFA in the $2\ \mu\text{m}$ region is thoroughly investigated. Amplifier gain and surviving channel power have been investigated in 20 WDM channels system by varying the input signal power in TDFA via adding or dropping channels. The modelling and simulations of unclamped and optical gain-clamped TDFA for application in WDM networks are performed.

It can be clearly observed that if the pump power factor is increased for GC-TDFA, the power excursion and the oscillation time are reduced because the laser achieves a stronger stabilization condition at high pump power. When 19 out of 20 channels are dropped, the output power excursion is about 4.3 dB when the gain amplifier is unclamped and only 0.0062 dB when the gain amplifier is clamped. The power excursion at unclamped gain is approximately the same with the experimental findings of a previous study. The results from both studies confirm the gain dynamic characteristics of unclamped TDFA and the big influence of drop/add channels on the power variation of the surviving channel.

Our findings revealed that the effects of power transients due to channel reconfigurations are significantly reduced by a feedback laser signal. Moreover, the dynamics of GC-TDFA are mainly influenced by the pump power factor, and the laser signal achieves a stronger stabilization

condition with increasing pump power factor. The design of the GC-TDFA should take into account the maximum input power variation to guarantee a stable dynamic control. As a conclusion, optical gain-clamping is an effective technique to eliminate power excursions due to the dynamic behavior of TDFA for optical WDM transmission system in the $2\ \mu\text{m}$ region. Our work can also be applied to other applications where the input power at the TDFA operating at $2\ \mu\text{m}$ region varies over time.

References

- [1] Z. Li, A. M. Heidt, J. M. O. Daniel, Y. Jung, S. U. Alam, and D. J. Richardson, Thulium-doped fiber amplifier for optical communications at $2\ \mu\text{m}$, *Opt. Exp.* 21(2013) 9289-9297.
- [2] P. J. Roberts, F. Couny, H. Sabert, B. J. Mangan, D. P. Williams, L. Farr, M. W. Mason, A. Tomlinson, T. A. Birks, J. C. Knight, and P. St.J. Russell, Ultimate low loss of hollow-core photonic crystal fibres, *Opt. Exp.* 13 (2005) 236-244.
- [3] N. Mac Suibhne, Z. Li, B. Baeuerle, and J. Zhao, WDM transmission at $2\ \mu\text{m}$ over low-loss hollow core photonic bandgap fiber, in *Optical Fiber Communication Conference/National Fiber Optic Engineers Conference 2013, OSA Technical Digest (online) (OSA, 2013)*, paper OW11.6.
- [4] Z. Li, S. U. Alam, J. M. O. Daniel, P. C. Shardlow, D. Jain, N. Simakov, A. M. Heidt, Y. Jung, J. K. Sahu, W. A. Clarkson, and D. J. Richardson, 90 nm gain extension towards $1.7\ \mu\text{m}$ for diode-pumped silica-based thulium-doped fiber amplifiers, in *Opt. Commun. (ECOC), European Conf.*, (2014) 1-3.
- [5] Z. Liu, Z. Li, and Y. Chen. 52.6Gbit/s single-channel directly-modulated optical transmitter for $2\ \mu\text{m}$ spectral region, *Opt. Fiber Commun. Conf., OSA, 2015*, paper Th1E.6.
- [6] B. Pal, *Guided Wave Optical Components and Devices: Basics, Technology, and Applications*, Amsterdam: Elsevier Academic Press, 2005, ch. 12, pp. 181-203.
- [7] J. Kim, S. S.-H. Yam, M. E. Marhic, and Y. Akasaka, Modeling gain dynamics of thulium-doped fiber amplifiers, *IEEE Photon. Technol. Lett.* 17 (2005) 998-1000.
- [8] S. S.-H. Yam, J. Kim, M. E. Marhic, Y. Akasaka, and L. G. Kazovsky, Gain dynamics of 14xxnm-pumped thulium-doped fiber amplifier, *IEEE Photon. Technol. Lett.* 16 (2004) 1646-1648.
- [9] M. Zannin, K. Ennsner, and S. Taccheo, On the benefits of optical gain-clamped amplification in optical burst switching networks, *J. Lightwave Technol.* 27 (2009) 5475-5482.
- [10] M. Karasek, A. Bononi, L.A. Rusch, and M. Menif, Gain stabilization in gain clamped EDFA cascades fed by burst-mode packet traffic, *J. Lightwave Technol.* 18 (2000) 308-313.
- [11] C. H. Kim, H. Yoon, S. B. Lee, C.-H. Lee, and Y. C. Chung, All-optical gain-controlled bidirectional add-drop amplifier using fiber Bragg gratings, *IEEE Photon. Technol. Lett.*, 12 (2000) 894-896.
- [12] K. Ennsner, Optical gain-clamped erbium-doped waveguide amplifier and its applications, *International Microwave & Optoelectronics Conf.*, 2007, Invited Paper.
- [13] M. Zirngibl, Gain control in erbium-doped fibre amplifiers by an all-optical feedback loop, *Electron. Lett.* 27 (1991) 560-561.
- [14] G. Luo, J. L. Zyskind, Y. Sun, A. K. Srivastava, J. W. Sulhoff, C. Wolf, M. A. Ali, Performance degradation of all-optical gain-clamped EDFAs due to relaxation-oscillations and spectral-hole burning in amplified WDM networks, *IEEE Photon. Technol. Lett.*, 9 (1997) 1346-1348.
- [15] S. Yam, Y. Akasaka, M.E. Marhic, and L.G. Kazovsky, Gain-clamped thulium-doped fibre amplifier with single pump at 1050 nm, *IEEE Photon. Technol. Lett.* 40 (2004) 628-629.
- [16] S. Aozasa, M. Shimizu, and H. Masuda, Gain spectrum control method for gain-shifted TDFA employing single wavelength pumping, *Electron. Lett.*, 38 (2002) 1325-1327.

- [17] K. Ennser and S. Taccheo, Investigation of transient response in cascaded gain-clamped erbium doped optical fiber amplifiers, *Electronic Lett.* 39 (2003) 1716-1717.
- [18] F. Wang, D. Y. Shen, H. Chen, D. Y. Fan, and Q. S. Lu, Modeling and optimization of stable gain-switched Tm-doped fiber lasers, *Opt. Rev.* 18 (2011) 360-364.
- [19] Z. Ren-Lai, J. You-Lun, Zhao, Y. Chao, and W. Yue-Zhu, A theoretical and experimental investigation of an in-band pumped gain-switched thulium-doped fiber laser, *Chin. Phys. B* 22 (2013) 0642081-86.
- [20] J. Yang, H. Li, Y. Tang, and J. Xu, Temporal characteristics of in-band pumped gain switched thulium-doped fiber lasers, *J. Opt. Soc.* 31(2014) 80-86.
- [21] S. D. Jackson and T. A. King., Theoretical modeling of Tm-doped silica fiber lasers, *J. Lightwave Technol.* 17 (1999) 948-956.
- [22] S. D. Agger and J. H. Povlsen, Emission and absorption cross section of thulium doped silica fibers, *Opt. Exp.* 14 (2006) 50-57.
- [23] F. Roy, D. Bayart, C. Heerdt, A. L. Souza, and P. Baniel, Spectral hole burning measurement in the thulium-doped fiber amplifier, in optical amplifier and their application, *OSA Technical Digest Series*, paper OWB3.
- [24] K. Ennser, G. Della Valle, M. Ibsen, J. Shmulovich, and S. Taccheo, Erbium-doped waveguide amplifier for reconfigurable WDM metro network, *IEEE Photon. Technol. Lett.* 17 (2005) 1468-1470.